



WHELEN AEROSPACE TECHNOLOGIES

Phone: (860) 526-9504
 Fax: (860) 526-2009
 Internet: www.flyWAT.com
 Sales/Service e-mail: info@flyWAT.com

**Installation Guide/ICA:
 Aviation model 9048202**

P/N 01-0790482-02

**LED Tail Position /
 Anti-Collision Light Assembly**

TSO-C30c TYPE III APPROVED
 TSO-C96a CLASS II APPROVED

The conditions and tests required for TSO approval of this article are minimum performance standards. Those installing this article either on or within a specific type or class of aircraft must determine that the aircraft installation conditions are within the TSO standards which include any accepted integrated non-TSO functions. TSO articles and any accepted integrated non-TSO function(s) must have separate approval for installation in an aircraft. The article may be installed only according to 14 CFR part 43 or the applicable airworthiness requirements.

SPECIFICATIONS:

Nominal Operational Voltage:28 VDC
 Input Current (with 7123403 Flasher):
 LED Tail Position Light:0.25 Amps
 LED Anti-Collision Light (Average):0.53 Amps
 LED Anti-Collision Light (Peak@0.25 sec.):2.8 Amps
 Flashrate45± 5 per min.

EQUIPMENT LIMITATIONS: An approved lighting system consists of three lights, one located on the tail and one located on each wingtip. The baseplate must be mounted parallel to the vertical and horizontal centerlines of the aircraft to project the patterns properly. The light assembly must be connected to flasher assembly, model 7123403.

Certain types of installations may require additional testing.

AIRWORTHINESS LIMITATIONS: The Airworthiness Limitations section is FAA approved and specifies inspections and other maintenance required under §43.16 and §91.403 of the Federal Aviation Regulations, unless an alternative program has been approved.

No airworthiness limitations are associated with the installation of the LED tail position/anti-collision light.

CONTINUED AIRWORTHINESS: The tail position light is designed with 4 LEDs. The anti-collision light is designed with 28 LEDs. If any one LED fails, the unit must be repaired or replaced. Note: To reduce eye strain, use an optical filter (such as dark glasses or blue covering dome) during inspection. Inspect the lens, replace if there is excessive scratching, pitting, discoloration or cracking. For additional lens maintenance detail see SAE ARP5637.

Note: The anti-collision light will automatically shut-off after 9-10 flashes if a failure is detected.

PERIODIC INSPECTIONS: An annual inspection shall be performed unless the OEM specifies a shorter interval.

INSTALLATION PROCEDURES:

- Using the mounting detail information on page 2, prepare the aircraft for means to secure the LED light assembly. Remove any existing mounting adapters.

- Connect the light inputs according to the chart shown. Connections to be in accordance with FAA approved methods.
- Install the light assembly by securing to the aircraft using appropriate, approved hardware. Refer to page 2. Insure that all leads are clear of any obstructions and secure as required. Insure that the gasket drain holes are oriented as shown on page 2.
- When necessary, waterproof the lightbase to aircraft. Apply single-part Silicone (RTV) or equivalent around any open area where water could get in. Do not cover the drain holes.
- Check all avionics systems for interference from this installation.
- A flight check should be performed by a properly certified pilot.
- If required, update aircraft records utilizing FAA Field Approval (Form 337) or equivalent.

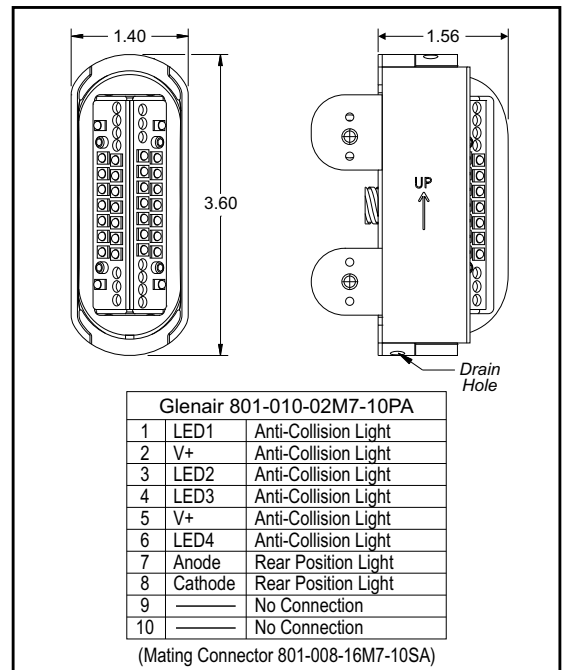

Aviation

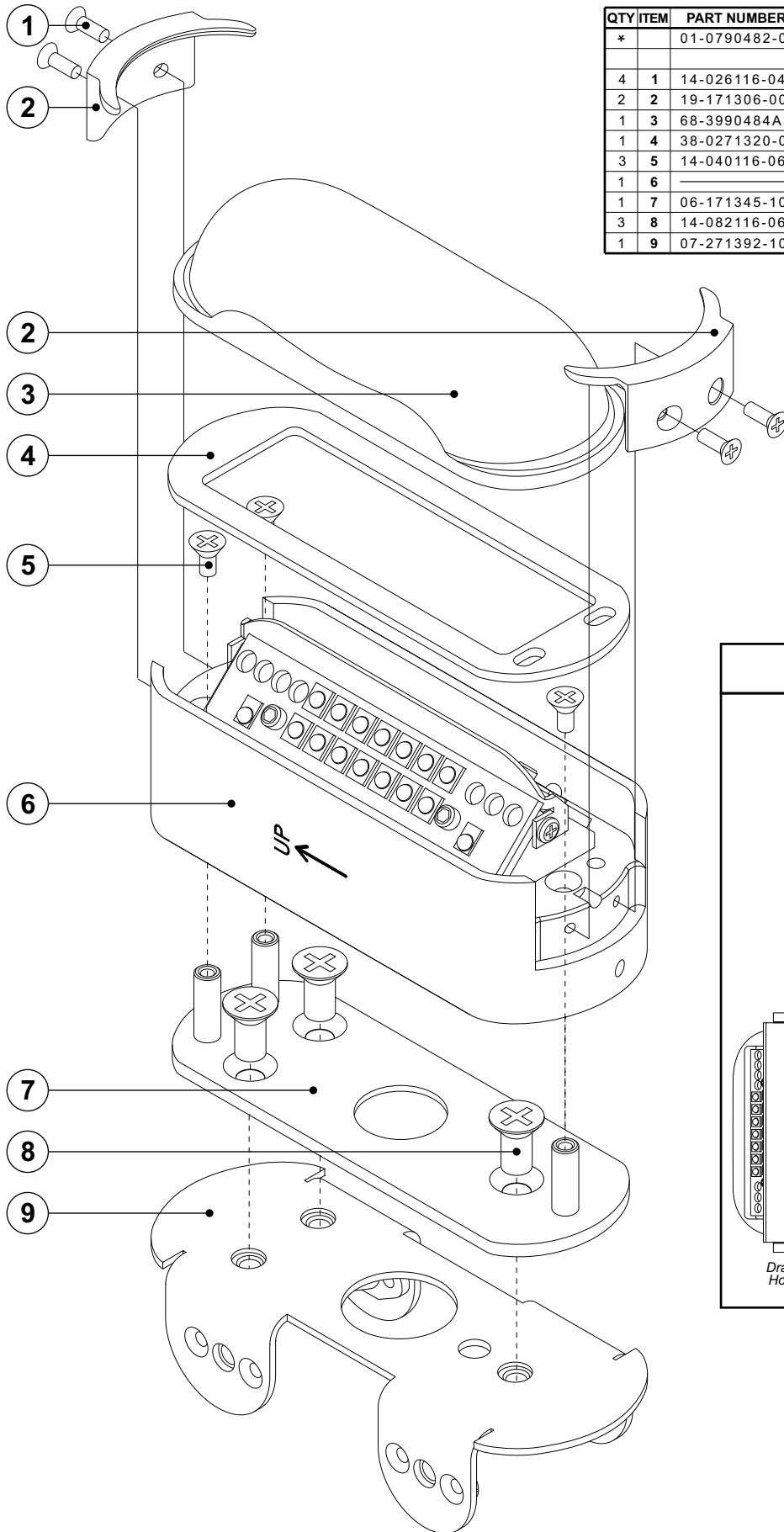

QTY	ITEM	PART NUMBER	DESCRIPTION
*		01-0790482-02	ASS'Y, TAIL/AC MODEL 9048202
4	1	14-026116-04P	SCREW, 2-56 X 1/4 P82FHMS SS
2	2	19-171306-000	RETAINER
1	3	68-3990484A30	LENS, HARDCOATED
1	4	38-0271320-00	GASKET, LENS
3	5	14-040116-060	SCREW, 4-40 X 3/8 PFHMS
1	6		ASS'Y, LIGHTHEAD MODEL 9048202
1	7	06-171345-100	BASE PLATE, MOUNTING MODEL 90482
3	8	14-082116-060	SCREW, #8-32 X 3/8 PFHMS
1	9	07-271392-100	BRACKET, MOUNTING MODEL 9048201

