

WHELEN[®]

ENGINEERING COMPANY INC.

51 Winthrop Road
 Chester, Connecticut 06412-0684
 Phone: (860) 526-9504
 Fax: (860) 526-2009
 Internet: www.whelen.com
 Sales/Service e-mail: aviation@whelen.com

Installation Guide: 90792()-series Model(s) 90792L4, 90792R4 P/N(s): 01-0790792-L4, 01-0790792-R4 LED Position/Anti-Collision 4/1 Light Assembly

TSO-C30c
 TYPE I, II, III
 APPROVED



TSO-C96a
 CLASS II
 APPROVED

The conditions and tests required for TSO approval of this article are minimum performance standards. It is the responsibility of those installing this article either on or within a specific type or class of aircraft to determine that the aircraft installation conditions are within the TSO standards. TSO articles must have separate approval for installation in aircraft. The article may be installed only if performed under 14 CFR part 43 or the applicable airworthiness requirements.

EQUIPMENT LIMITATIONS: An approved forward lighting system consists of two lights, one located on each wingtip. The baseplate must be mounted parallel to the vertical and horizontal centerlines of the aircraft to project the patterns properly. A separate power supply unit (PSU) such as model 9079704 is required for each light assembly.

Certain types of aircraft may require additional testing.

The Red Anti-Collision light is a non-TSO function.

CONTINUED AIRWORTHINESS: The forward position light is designed with 4 Green or 5 Red LEDs. The tail position light is designed with 2 LEDs. The white anti-collision light is designed with 12 LEDs. The red anti-collision light is designed with 18 LEDs. If any one bank of LEDs fail, the PSU assembly should be checked. If the PSU checks good, replace the lighthouse. If one position light LED fails, the unit must be repaired or replaced.

For the White Anti-Collision light - If a single forward-facing and/or a single aft-facing LED fails in a shorted mode, the unit is still FAR compliant.

For the Red Anti-Collision light - If three or more forward-facing and/or three or more aft-facing LEDs fail in a shorted mode, the unit should be replaced.

Note: To reduce eye strain use an optical filter such as dark glasses or a blue covering dome during LED inspection.

Inspect the lens. Replace if there is excessive scratching, pitting, discoloration or cracking.

CLEANING: Use only products compatible with polycarbonate to clean the outer lens. Follow the manufacturer's instructions. Use of other chemicals could result in premature lens cracking (crazing) and discoloration. Do not use a pressure washer to clean this product.

INSTALLATION PROCEDURES: The following information provides guidelines for the installation of a Whelen LED position/anti-collision light. Please refer to the OEM manual for your aircraft for specific removal and installation instructions.

1. Choose the appropriate light assembly.
2. Using the mounting detail information provided, prepare the aircraft for means to secure the light assembly.
3. Carefully remove the screws and lens retainers. Remove the lens and gasket from the light assembly.
CAUTION: Do not touch the LED with either fingers or sharp objects. This could soil and/or damage the LED and effect the optical performance of the light.
4. Using the appropriate hardware install the baseplate to the aircraft. Insure that all leads are clear of any obstructions and secured as required. Waterproof the light base to the aircraft. Apply sealant around the base where water could get in or install gasket 38-0271817-00 (sold separately). If used, install gasket with slot down.
5. Reinstall lens gasket, lens and lens retainers. Confirm proper gasket fit. Reinsert screws and tighten lightly.
6. Connect the light inputs according to the chart shown. Connections to be in accordance with FAA approved methods.

D38999 / 26FC-8PN		
A	AC1	WHITE ACL CATHODE AFT
B	AC2	WHITE ACL CATHODE FWD
C	AC3	RED ACL CATHODE AFT
D	AC4	RED ACL CATHODE FWD
E	ACV+	ACL ANODE
F	CNTL	SYNC CONTROL
G	POSV+	POSITION LIGHT ANODE
H	POS RET	POSITION LIGHT CATHODE

7. Check all avionics systems for interference from this installation.
8. A flight check should be performed by a properly certified pilot.
9. Update aircraft records, Complete Form 337 and obtain FAA field approval for installation, as necessary.

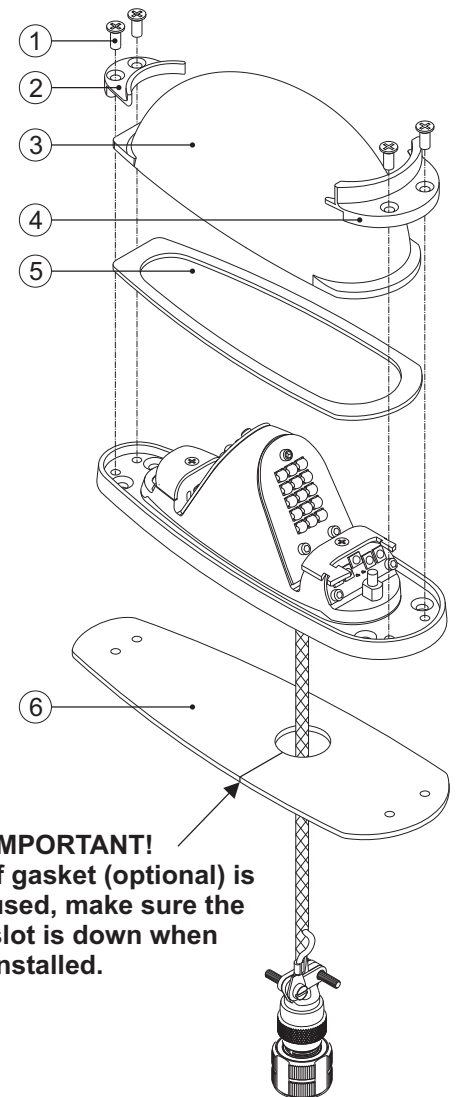
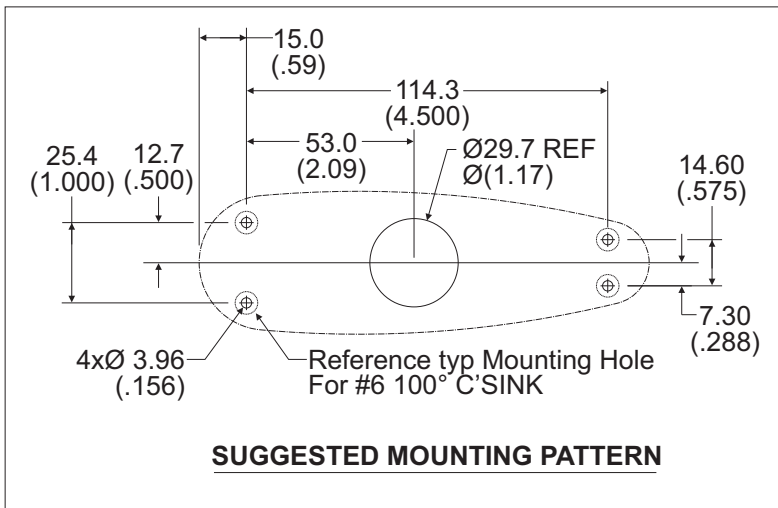
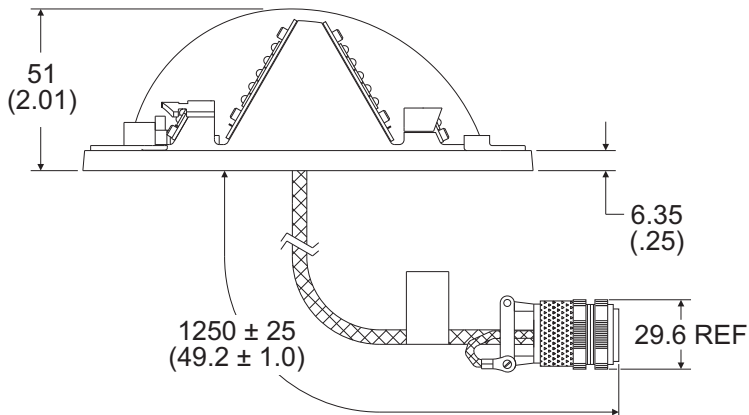
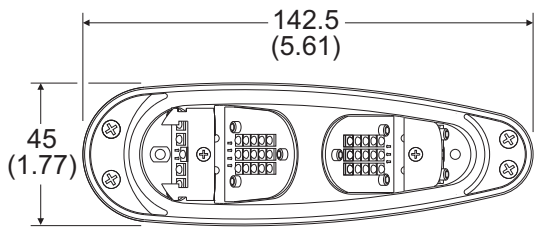

QTY	ITEM	PART NUMBER	DESCRIPTION
4	1	MS24693-3B	Screw, 4-40 x 5/16 P100FH/CSK BLK
1	2	19-151003-100	Retainer, Lens, Rear
1	3	68-3990574A30	Lens, Clear, Hardcoated
1	4	19-171471-100	Retainer, Lens, Front
1	5	38-0231219-00	Gasket, Lens
1	6	38-0271817-00	Gasket (Option not included)