

WHELEN[®]

ENGINEERING COMPANY INC.

51 Winthrop Road,
Chester, Connecticut 06412-0684
Phone: (860) 526-9504

Installation Guide: PAR-46 LED Hand Held Light

Internet: www.whelen.com
Sales e-mail: autosale@whelen.com
Customer Service e-mail: custserv@whelen.com

⚠ WARNING: This product can expose you to chemicals including Methylene Chloride which is known to the State of California to cause cancer, and Bisphenol A, which is known to the State of California to cause birth defects or other reproductive harm. For more information go to www.P65Warnings.ca.gov.

IMPORTANT AIR BAG WARNING!

Do not install this product or route any wires in the air bag deployment zone of your vehicle. Equipment mounted or located in air bag deployment zones will damage or reduce the effectiveness of the air bag, or become a projectile that could cause serious personal injury or death. Refer to your vehicle owner's manual to learn the air bag deployment zones for the vehicle.

The User/Installer assumes full responsibility to determine the proper mounting location, based on providing ultimate safety to all passengers inside the vehicle.

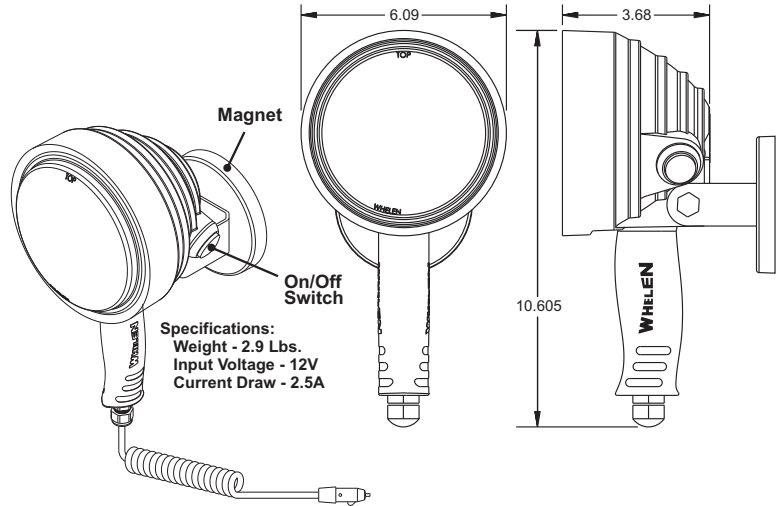

©2011 Whelen Engineering Company Inc.
Form No.14458 (012711)

For warranty information regarding this product, visit www.whelen.com/warranty

WHELEN[®]

ENGINEERING COMPANY INC.

51 Winthrop Road,
Chester, Connecticut 06412-0684
Phone: (860) 526-9504

Installation Guide: PAR-46 LED Hand Held Light

Internet: www.whelen.com
Sales e-mail: autosale@whelen.com
Customer Service e-mail: custserv@whelen.com

⚠ WARNING: This product can expose you to chemicals including Methylene Chloride which is known to the State of California to cause cancer, and Bisphenol A, which is known to the State of California to cause birth defects or other reproductive harm. For more information go to www.P65Warnings.ca.gov.

IMPORTANT AIR BAG WARNING!

Do not install this product or route any wires in the air bag deployment zone of your vehicle. Equipment mounted or located in air bag deployment zones will damage or reduce the effectiveness of the air bag, or become a projectile that could cause serious personal injury or death. Refer to your vehicle owner's manual to learn the air bag deployment zones for the vehicle.

The User/Installer assumes full responsibility to determine the proper mounting location, based on providing ultimate safety to all passengers inside the vehicle.

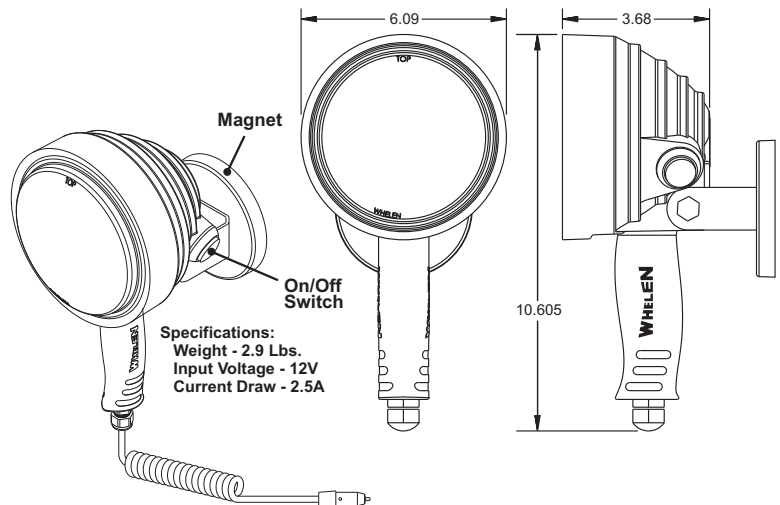

©2011 Whelen Engineering Company Inc.
Form No.14458 (012711)

For warranty information regarding this product, visit www.whelen.com/warranty