

51 Winthrop Road
Chester, Connecticut 06412-0684
Phone: (860) 526-9504
Sales Email: autosale@whelen.com
Canadian Sales: canadiansales@whelen.com
Customer Service: custserv@whelen.com

Safety First: This document provides all the necessary information to allow your Whelen product to be properly and safely installed. Before beginning the installation and/or operation of your new product, the installation technician and operator must read this manual completely. Important information is contained herein that could prevent serious injury or damage.

- Proper installation of this product requires the installer to have a good understanding of automotive electronics, systems and procedures.
- Whelen Engineering requires the use of waterproof butt splices and/or connectors if that connector could be exposed to moisture.
- Failure to use specified installation parts and/or hardware will void the product warranty!
- If mounting this product requires drilling holes, the installer **MUST** be sure that no vehicle components or other vital parts could be damaged by the drilling process. Check both sides of the mounting surface before drilling begins. Also de-burr any holes and remove any metal shards or remnants. Install grommets into all wire passage holes.
- Do not install this product or route any wires in the deployment area of your air bag. Equipment mounted or located in the air bag deployment area will damage or reduce the effectiveness of the air bag, or become a projectile that could cause serious personal injury or death. Refer to your vehicle owner's manual for the air bag deployment area. The User/Installer assumes full responsibility to determine proper mounting location, based on providing ultimate safety to all passengers inside the vehicle.
- For this product to operate at optimum efficiency, a good electrical connection to chassis ground must be made. The recommended procedure requires the product ground wire to be connected directly to the **NEGATIVE (-)** battery post.
- Do not attempt to activate or control this device in a hazardous driving situation.
- If this product uses a remote device to activate or control this product, make sure that this control is located in an area that allows both the vehicle and the control to be operated safely in any driving condition.
- This product contains high-intensity LEDs. Do not stare directly into these lights. Momentary blindness and/or eye damage could result.
- Use only soap and water to clean the outer lens. Use of other chemicals could result in premature lens cracking (crazing) and discoloration. Lenses in this condition have significantly reduced effectiveness and should be replaced immediately. Inspect and operate this product regularly to confirm its proper operation and mounting condition. Do not use a pressure washer to clean this product.
- **WARNING!** All customer supplied wires that connect to the positive (+) terminal of the battery must be sized to supply at least 125% of the maximum operating current and **FUSED** "at the battery" to carry that load. **DO NOT USE CIRCUIT BREAKERS WITH THIS PRODUCT!**
- **FAILURE TO FOLLOW THESE PRECAUTIONS AND INSTRUCTIONS COULD RESULT IN DAMAGE TO THE PRODUCT OR VEHICLE AND/OR SERIOUS INJURY TO YOU AND YOUR PASSENGERS!**

NOTICE! Prior to installing on any vehicle, check your state motor vehicle codes to confirm that this product complies with any and all state statutes.

Installation: Refer to the diagrams shown for mounting measurements specific to your model.

1. Using the mounting diagram shown, mark the locations for the mounting holes and the wire passage hole. Using a .250" drill bit, drill 4 mounting holes. Drill and de-burr a 1.75" dia. wire passage hole in the location shown.
2. Insert the screw grommet flange into the mounting holes as shown.
3. Using appropriately sized wire, extend the wires through the gasket and through the wire passage hole. Make the appropriate connections (see wiring diagram for fusing information) and confirm proper operation of the light.
4. Combine the lighthead and trim flange in the order shown. While holding these components together, place this assembly onto the screw grommet flange.
5. Hold the components firmly against the mounting surface and secure to the mounting surface using the hardware provided.

Wiring:

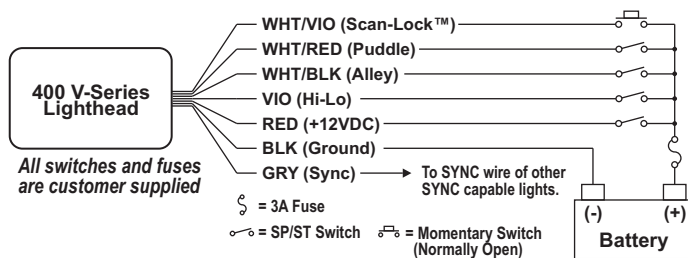

Waterproof butt splices and/or connectors are required if that connection could be exposed to moisture. Any unused wires must be sealed (waterproofed) to prevent moisture infiltration.

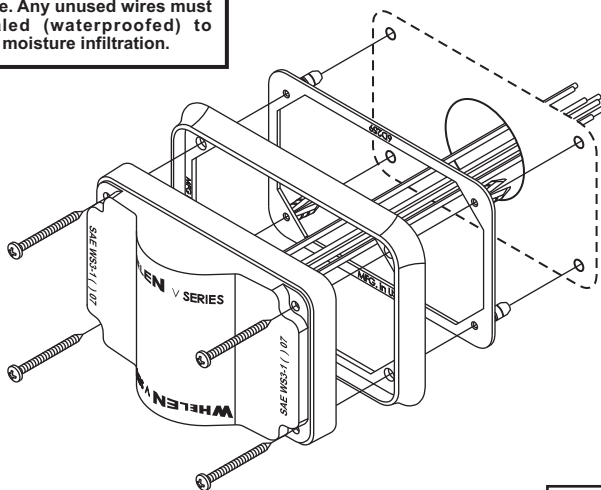

Operation:

Scan-Lock™: To advance pattern: With the lighthead active, apply +VBAT to the WHT/VIO wire for less than 1 second. To cycle to previous patterns: Apply +VBAT for more than 1 second. To restore factory default pattern: Turn off power to the lighthead. Apply +VBAT to the WHT/VIO wire while turning the lighthead on. Continue to apply voltage to the WHT/VIO wire for 5 seconds.

Hi-Lo Operation: To reduce the light output for nighttime operation, apply +12VDC to the VIO wire. Remove voltage to restore full light output. A Single Pole/Single Throw switch is best suited for this use.

SYNC Operation: Some of the patterns available for the standard SYNC lighthead are described as being either Phase 1 (PH.1) or Phase 2 (PH.2). These terms define how patterns on lightheads with their SYNC wires connected relate to each other. Lightheads configured to display the same Phase of a given pattern (Phase 1 or Phase 2) will flash simultaneously. Lightheads configured to Phase 2 of a given pattern will alternate with Phase 1 lightheads. A normally open momentary switch is best suited for this use.

NOTE: The SYNC wire can be connected to other SYNC-capable power supplies to synchronize their output. Be sure to cap the SYNC wire if it is not used.

Pattern List:

#	Name	Cert.	#	Name	Cert.
1.	SignalAlert™ PH1	1,2,3,4	17.	SingleFlash 60	1,2, 4
2.	SignalAlert PH2	1,2,3,4	18.	SingleFlash 90	1,2,3,4
3.	ComAlert™ 75 PH1	1,2,3,4	19.	SingleFlash 120	1,2,3,4
4.	ComAlert 75 PH2	1,2,3,4	20.	SingleFlash 240	1, 3,4
5.	Comet Flash® PH1	1,2,3,4	21.	DoubleFlash 120	1,2,3,4
6.	Comet Flash PH2	1,2,3,4	22.	TripleFlash 120	1,2,3,4
7.	LongBurst™ PH1	1,2,3,4	23.	ComAlert™ 150	1, 3,4
8.	LongBurst PH2	1,2,3,4	24.	PingPong™ 120	1,2,3,4
9.	PingPong™ 75 PH1	1,2,3,4	25.	ActionFlash™ 60	1,2, 4
10.	PingPong 75 PH2	1,2,3,4	26.	ActionFlash 120	1,2,3,4
11.	SingleFlash 75 PH1	1,2,3,4	27.	Action SF 60/120	1,2, 4
12.	SingleFlash 75 PH2	1,2,3,4	28.	Action SF 120/TF75	1,2,3,4
13.	DoubleFlash 75 PH1	1,2,3,4	29.	ModuFlash	
14.	DoubleFlash 75 PH2	1,2,3,4	30.	CalScan	1,2,3,4
15.	TripleFlash™ 75 PH1	1,2,3,4	31.	ActionScan	1, 3,4
16.	TripleFlash 75 PH2	1,2,3,4	32.	STEADY	

Bold = SYNC Pattern
PH1 = Phase 1 PH2 = Phase 2

Note: Each pattern is certified compliant in up to 4 classifications, shown in the "Cert" column:

1. SAE
2. CA Title XIII
3. NFPA
4. KKK

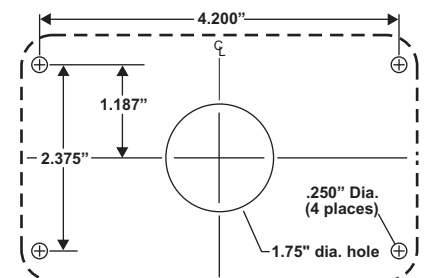

For replacement part numbers and other helpful information, visit www.whelen.com/install

For warranty information regarding this product, visit www.whelen.com/warranty

Warnings to Installers

Whelen's emergency vehicle warning devices must be properly mounted and wired in order to be effective and safe. Read and follow all of Whelen's written instructions when installing or using this device. Emergency vehicles are often operated under high speed stressful conditions which must be accounted for when installing all emergency warning devices. Controls should be placed within convenient reach of the operator so that he can operate the system without taking his eyes off the roadway. Emergency warning devices can require high electrical voltages and/or currents. Properly protect and use caution around live electrical connections. Grounding or shorting of electrical connections can cause high current arcing, which can cause personal injury and/or vehicle damage, including fire. Many electronic devices used in emergency vehicles can create or be affected by electromagnetic interference. Therefore, after installation of any electronic device it is necessary to test all electronic equipment simultaneously to insure that they operate free of interference from other components within the vehicle. Never power emergency warning equipment from the same circuit or share the same grounding circuit with radio communication equipment. All devices should be mounted in accordance with the manufacturer's instructions and securely fastened to vehicle elements of sufficient strength to withstand the forces applied to the device. Driver and/or passenger air bags (SRS) will affect the way equipment should be mounted. This device should be mounted by permanent installation and within the zones specified by the vehicle manufacturer, if any. Any device mounted in the deployment area of an air bag will damage or reduce the effectiveness of the air bag and may damage or dislodge the device. Installer must be sure that this device, its mounting hardware and electrical supply wiring does not interfere with the air bag or the SRS wiring or sensors. Mounting the unit inside the vehicle by a method other than permanent installation is not recommended as unit may become dislodged during swerving; sudden braking or collision. Failure to follow instructions can result in personal injury. Whelen assumes no liability for any loss resulting from the use of this warning device. **PROPER INSTALLATION COMBINED WITH OPERATOR TRAINING IN THE PROPER USE OF EMERGENCY WARNING DEVICES IS ESSENTIAL TO INSURE THE SAFETY OF EMERGENCY PERSONNEL AND THE PUBLIC.**

Warnings to Users

Whelen's emergency vehicle warning devices are intended to alert other operators and pedestrians to the presence and operation of emergency vehicles and personnel. However, the use of this or any other Whelen emergency warning device does not guarantee that you will have the right-of-way or that other drivers and pedestrians will properly heed an emergency warning signal. Never assume you have the right-of-way. It is your responsibility to proceed safely before entering an intersection, driving against traffic, responding at a high rate of speed, or walking on or around traffic lanes. Emergency vehicle warning devices should be tested on a daily basis to ensure that they operate properly. When in actual use, the operator must ensure that both visual and audible warnings are not blocked by vehicle components (i.e.: open trunks or compartment doors), people, vehicles, or other obstructions. It is the user's responsibility to understand and obey all laws regarding emergency warning devices. The user should be familiar with all applicable laws and regulations prior to the use of any emergency vehicle warning device. Whelen's audible warning devices are designed to project sound in a forward direction away from the vehicle occupants. However, because sustained periodic exposure to loud sounds can cause hearing loss, all audible warning devices should be installed and operated in accordance with the standards established by the National Fire Protection Association.