

WHELEN[®]

ENGINEERING COMPANY

51 Winthrop Road
Chester, Connecticut 06412-0684
Phone: (860) 526-9504
Internet: www.whelen.com
Sales e-mail: autosale@whelen.com
Customer Service e-mail: custserv@whelen.com

Mounting Guide:
Arges™ Control Head
Bail Mount Bracket
Model: ARGCH1

WARNING! Do not install this product or route any wires in the deployment area of your air bag. Equipment mounted or located in the air bag deployment area will damage or reduce the effectiveness of the air bag, or become a projectile that could cause serious personal injury or death. Refer to your vehicle owner's manual for the air bag deployment area. The User/Installer assumes full responsibility to determine proper mounting location, based on providing ultimate safety to all passengers inside the vehicle.

1. If not already mounted, secure the adapter plate to the Arges control head as shown (Fig. 1).
2. Position the Bail Bracket onto the proposed mounting surface. Using an awl or suitable tool, mark the location of the pilot holes to be drilled. **Important! Make sure that no vehicle components or other vital parts could be damaged by the drilling process. Check both sides of the mounting surface before drilling begins. Also de-burr the holes and remove any metal shards or remnants before proceeding.**
3. Drill the pilot holes in the areas marked in the previous step. The size of the drill bit should be determined by the size of the mounting hardware (#10 sheet metal screws) and the thickness of the mounting surface.
4. Using the hardware provided, secure the Bail Bracket firmly to the mounting surface (Fig. 2).
5. Secure the Control Head/Adapter Plate assembly onto the swivel mount bracket as shown and secure using the hardware provided.

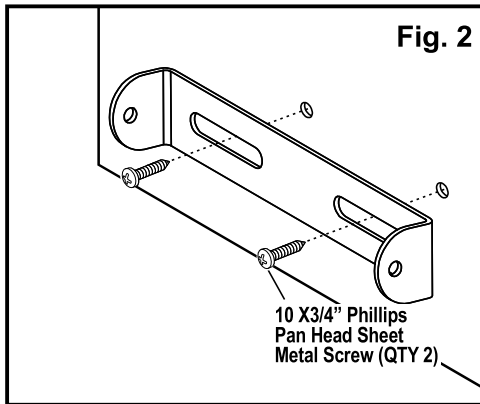
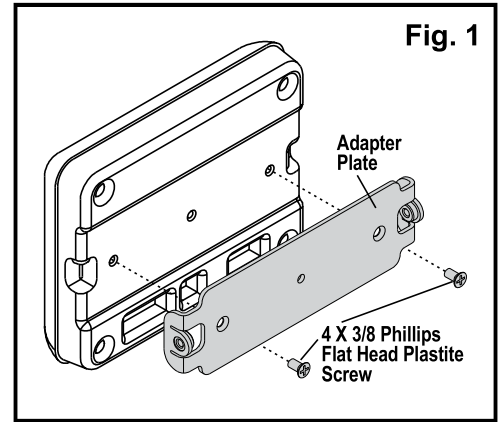

Note: It may be easier to connect the Controller Pigtail to the Control Head before the control head is mounted to the bail mount bracket. Refer to the manual included with your Arges™ for detailed wiring and operating information

