

WHELEN[®]

ENGINEERING COMPANY INC.

51 Winthrop Road
Chester, Connecticut 06412-0684
Phone: (860) 526-9504
Internet: www.whelen.com
Sales e-mail: autosale@whelen.com
Customer Service e-mail: custserv@whelen.com

Installation Guide:
FastTrax™ System
Model FTF5

Warnings to Installers

Whelen's emergency vehicle warning devices must be properly mounted and wired in order to be effective and safe. Read and follow all of Whelen's written instructions when installing or using this device. Emergency vehicles are often operated under high speed stressful conditions which must be accounted for when installing all emergency warning devices. Controls should be placed within convenient reach of the operator so that they can operate the system without taking their eyes off the roadway. Emergency warning devices can require high electrical voltages and/or currents. Properly protect and use caution around live electrical connections. Grounding or shorting of electrical connections can cause high current arcing, which can cause personal injury and/or vehicle damage, including fire. Many electronic devices used in emergency vehicles can create or be affected by electromagnetic interference. Therefore, after installation of any electronic device it is necessary to test all electronic equipment simultaneously to insure that they operate free of interference from other components within the vehicle. Never power emergency warning equipment from the same circuit or share the same grounding circuit with radio communication equipment. All devices should be mounted in accordance with the manufacturer's instructions and securely fastened to vehicle elements of sufficient strength to withstand the forces applied to the device. Driver and/or passenger air bags (SRS) will affect the way equipment should be mounted. This device should be mounted by permanent installation and within the zones specified by the vehicle manufacturer, if any. Any device mounted in the deployment area of an air bag will damage or reduce the effectiveness of the air bag and may damage or dislodge the device. Installer must be sure that this device, its mounting hardware and electrical supply wiring does not interfere with the air bag or the SRS wiring or sensors. Mounting the unit inside the vehicle by a method other than permanent installation is not recommended as unit may become dislodged during swerving; sudden braking or collision. Failure to follow instructions can result in personal injury. Whelen assumes no liability for any loss resulting from the use of this warning device. **PROPER INSTALLATION COMBINED WITH OPERATOR TRAINING IN THE PROPER USE OF EMERGENCY WARNING DEVICES IS ESSENTIAL TO INSURE THE SAFETY OF EMERGENCY PERSONNEL AND THE PUBLIC.**

Warnings to Users

Whelen's emergency vehicle warning devices are intended to alert other operators and pedestrians to the presence and operation of emergency vehicles and personnel. However, the use of this or any other Whelen emergency warning device does not guarantee that you will have the right-of-way or that other drivers and pedestrians will properly heed an emergency warning signal. Never assume you have the right-of-way. It is your responsibility to proceed safely before entering an intersection, driving against traffic, responding at a high rate of speed, or walking on or around traffic lanes. Emergency vehicle warning devices should be tested on a daily basis to ensure that they operate properly. When in actual use, the operator must ensure that both visual and audible warnings are not blocked by vehicle components (i.e.: open trunks or compartment doors), people, vehicles, or other obstructions. It is the user's responsibility to understand and obey all laws regarding emergency warning devices. The user should be familiar with all applicable laws and regulations prior to the use of any emergency vehicle warning device. Whelen's audible warning devices are designed to project sound in a forward direction away from the vehicle occupants. However, because sustained periodic exposure to loud sounds can cause hearing loss, all audible warning devices should be installed and operated in accordance with the standards established by the National Fire Protection Association.

Safety First

This document provides all the necessary information to allow your Whelen product to be properly and safely installed. Before beginning the installation and/or operation of your new product, the installation technician and operator must read this manual completely. Important information is contained herein that could prevent serious injury or damage.

- **Proper installation of this product requires the installer to have a good understanding of automotive electronics, systems and procedures.**
- **Whelen Engineering requires the use of waterproof butt splices and/or connectors if that connector could be exposed to moisture.**
- **Any holes, either created or utilized by this product, should be made both air- and watertight using a sealant recommended by your vehicle manufacturer.**
- **Failure to use specified installation parts and/or hardware will void the product warranty.**
- **If mounting this product requires drilling holes, the installer MUST be sure that no vehicle components or other vital parts could be damaged by the drilling process. Check both sides of the mounting surface before drilling begins. Also de-burr the holes and remove any metal shards or remnants. Install grommets into all wire passage holes.**
- **If this manual states that this product may be mounted with suction cups, magnets, tape or Velcro®, clean the mounting surface with a 50/50 mix of isopropyl alcohol and water and dry thoroughly.**
- **Do not install this product or route any wires in the deployment area of your air bag. Equipment mounted or located in the air bag deployment area will damage or reduce the effectiveness of the air bag, or become a projectile that could cause serious personal injury or death. Refer to your vehicle owner's manual for the air bag deployment area. The User/Installer assumes full responsibility to determine proper mounting location, based on providing ultimate safety to all passengers inside the vehicle.**
- **For this product to operate at optimum efficiency, a good electrical connection to chassis ground must be made. The recommended procedure requires the product ground wire to be connected directly to the NEGATIVE (-) battery post (this does not include products that use cigar power cords).**
- **If this product uses a remote device for activation or control, make sure that this device is located in an area that allows both the vehicle and the device to be operated safely in any driving condition.**
- **Do not attempt to activate or control this device in a hazardous driving situation.**
- **This product contains either strobe light(s), halogen light(s), high-intensity LEDs or a combination of these lights. Do not stare directly into these lights. Momentary blindness and/or eye damage could result.**
- **Use only soap and water to clean the outer lens. Use of other chemicals could result in premature lens cracking (crazing) and discoloration. Lenses in this condition have significantly reduced effectiveness and should be replaced immediately. Inspect and operate this product regularly to confirm its proper operation and mounting condition. Do not use a pressure washer to clean this product.**
- **It is recommended that these instructions be stored in a safe place and referred to when performing maintenance and/or reinstallation of this product.**
- **FAILURE TO FOLLOW THESE SAFETY PRECAUTIONS AND INSTRUCTIONS COULD RESULT IN DAMAGE TO THE PRODUCT OR VEHICLE AND/OR SERIOUS INJURY TO YOU AND YOUR PASSENGERS!**

Mounting The Power Supply...

While the ISP8HS Strobe/Halogen power supply will be mounted in the vehicle's trunk, the installation technician should keep the following recommendations in mind:

- A) The unit should be mounted on a metal surface to aid heat dissipation. Be sure that this surface is not one that either generates or is exposed to excessive heat during normal operation of the vehicle.
- B) Do not select a location where the power supply will be exposed to potential damage from any unsecured or loose equipment in the vehicle.
- C) Be sure the area selected will not allow the ISP8HS to be exposed to water!
- D) When routing the wires, it is important to choose a path that will keep these wires away from excessive heat and from any vehicle equipment that could compromise the integrity of the wires (trunk lids, door jams, etc.).

Using appropriately sized wires, connect the power supply to the battery using the wiring diagram on page 7 as a guide. Be sure to include the specified size fuse, keeping in mind that there should not be more than two feet of wire between the fuse block and the positive battery terminal.

WARNING: All customer supplied wires, that connect to the positive (+) terminal of the battery, must be sized to supply at least 125% of the maximum operating current, and fused "at the battery" to carry the load!

CAUTION: As it will be necessary to drill holes into the mounting surface, the installer **MUST** be sure that no vehicle components or other vital parts could be damaged by the drilling process. Check both sides of the mounting surface before drilling begins!

Using the hardware provided, secure the power supply to its mounting surface.

Vehicle preparation...

Note: This section will outline the vehicle preparation procedures for installation of the FastTrax™ model FTF5 *without* the FastTrax model FTT1 Traffic Advisor™ module. If the FTT1 is present, please refer to the FTT1 installation manual included with the module.

1. Remove the rear seat back, C-pillar covers and headliner from the vehicle.
2. Locate the passenger-side roof support brace. This brace runs from front to back above both the front and rear doors on both sides of the vehicle. On this brace, locate the first "squared" opening from the front.

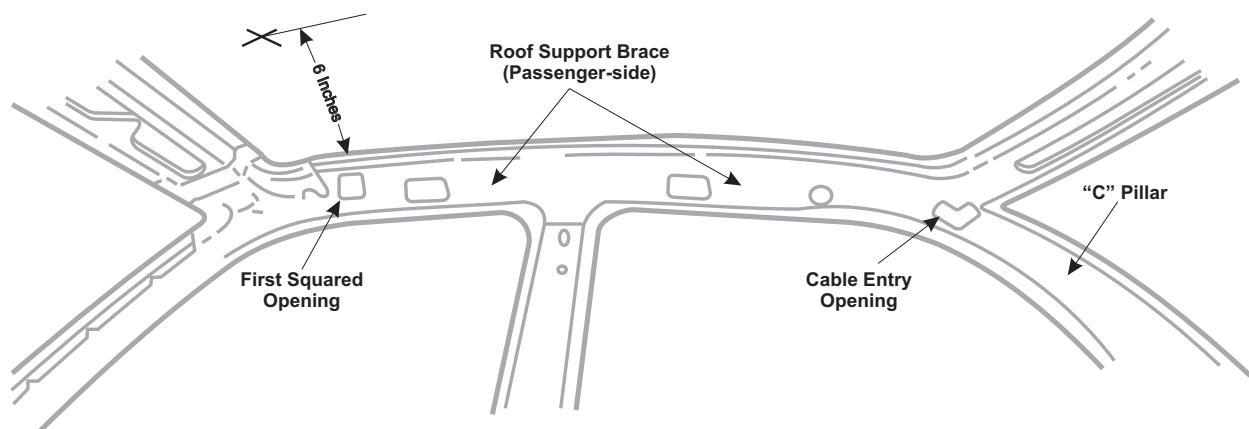

3. Measure a line perpendicular to the centerline of the vehicle from the middle of the top edge of this square, to a distance of 6" directly towards the centerline of the vehicle. Mark this point. Using a 1/8" (0.125") drill bit, drill a pilot hole up through the roof at this location.
4. Using this hole as a center point, cut a 1" hole down through the roof. De-burr this hole and install a grommet. This is to be used as the passenger-side cable passage hole.
5. Use steps 2 through 4 as a guide to creating a similar hole for the driver-side cable passage hole.

Be sure to de-burr the hole using a round (shown) or similar file before installing the grommet.

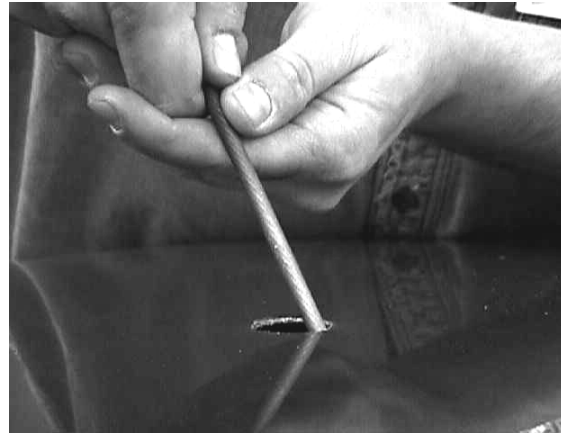

Cable preparation and routing...

Before the lighthead cables can be routed through the vehicle, they must first be prepared. Tag the 8 cables to be used for the strobe lighthead (3-conductor) with the tags numbered **S1** through **S8**, and the 2 cables to be used for the halogen lighthead (2-conductor) with tags **H4** and **H8**. This will insure that the lighthead is connected to their proper power supply port. A lighthead's identity is determined by what power supply port they are to be connected to.

Note: Before the cables are routed, the installer may wish to apply a light coating of silicone spray to the cable's outer jacket. This will allow the cables to be routed more easily.

The following section demonstrates how these cables should be routed. Locate the four, 3-conductor strobe cables tagged S2, S4, S6, S8 and the 2-conductor cable tagged H1. These cables (like all of the cables) have one end with pinned terminals on the wires and one end with socket terminals on the wires. Orient these cables so that all the pinned-ends of the cables are together and all the socketed-ends of the cables are together. Bundle the socketed-end of these cables securely together with electrical tape. Now locate the cable entry opening in the "C" pillar shown above.

Passenger-side cable entry opening

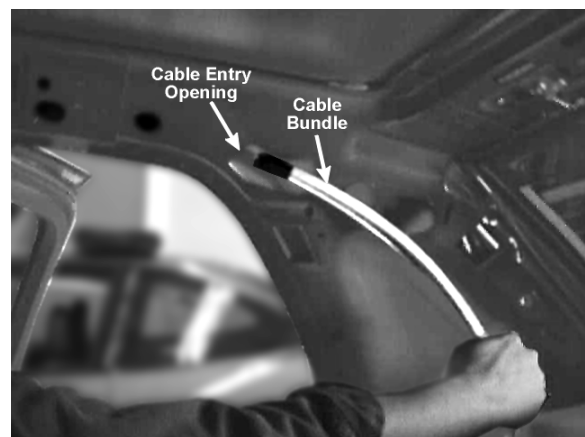

Feed this bundle thru the side brace cable entry opening in the "C" pillar and through the support brace until it exits out of the cable exit opening shown in this picture. Route the cable bundle up through the grommets hole. Be sure to pass a minimum of 18" of cable through this hole and out onto the roof.

Apply a generous amount of RTV to the grommet hole to completely waterproof this opening.



Cable bundle exiting passenger-side cable exit opening

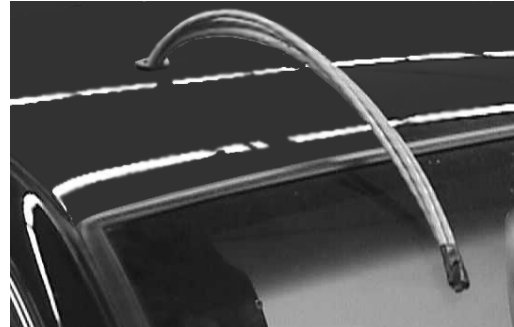

Cable bundle exiting passenger-side cable access hole

Insert the remaining pinned end of the cable bundle through the cable entry opening in the "C" pillar and down through the "C" pillar until it enters the trunk area of the vehicle. In the trunk, route the cable bundle towards the ISP8HS. The basic cable path is as shown.

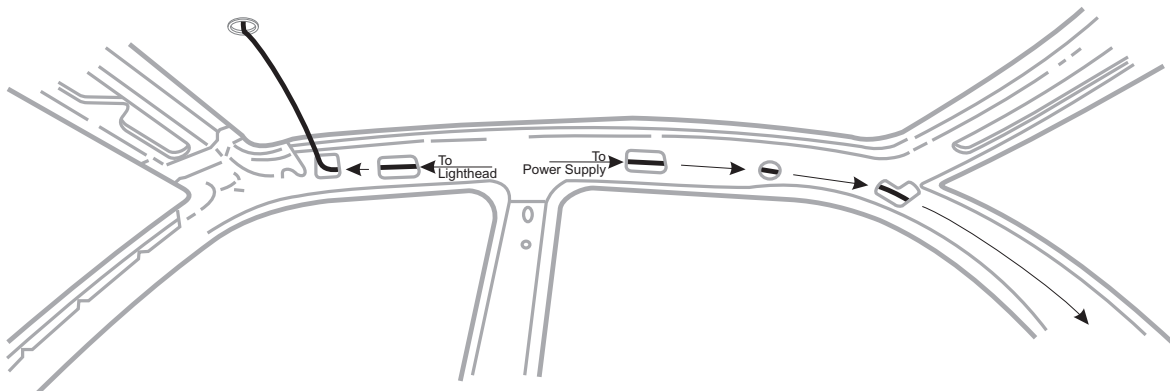

Repeat this entire procedure using a cable bundle consisting of the remaining cables (S1, S3, S5, S7 and H4) bundled together and routed along the driver-side support brace.

Insert the cable wire terminals into their plug connectors as follows:

Strobe Cable

- Pin #1 - **RED**
- Pin #2 - **BLACK**
- Pin #3 - **WHITE**

Halogen Cable

- Pin #1 - **WHITE**
- Pin #2 - **NO CONNECTION**
- Pin #3 - **BLACK**

The FastTrax™ housing mounting surface will now be prepared.

Surface Preparation

IMPORTANT NOTICE!!!

The FastTrax™ system housing is secured to the vehicle using 3M™ VHB™ double-sided tape. This tape offers superior bond strength that allows the FastTrax™ to be exposed to inclement weather with no adhesion loss. However, the key to successful bonding lies in proper preparation of the mounting surface. The following section will outline the recommended procedure for mounting surface preparation. Your FastTrax™ system includes the 3M™ recommended preparation solution. **DO NOT USE ANY OTHER SOLUTIONS TO PREPARE THE MOUNTING SURFACE!** By following these procedures, your FastTrax™ installation will produce a successful bond with lasting adhesion. The outer surface of the vehicle must be at least 65°F before proceeding!

1. **Without** removing the protective backing from the mounting tape, position the FastTrax housing onto its mounting surface. The housing is properly positioned when it is centered on the vehicle roof with a 1/8" space between the leading edge of the housing and the windshield gasket.
2. Any part of the vehicle that will be in contact with the adhesive tape PLUS an additional inch and a half (1½) wide area on either side of the tape will have to be prepared. This area is called the bonding surface. Remove the FastTrax housing from the vehicle.
3. The bonding surface must be completely clean and dry. Using a clean lint-free cloth, clean the bonding surface with an automotive wax and grease remover (ex:Prepsol®). Allow to dry thoroughly.
4. Shake the "3M Keel Primer" applicator (included) well before using. Following the instructions attached to the applicator, apply a thin uniform coating to the bonding surface using the minimum amount that will fully coat the surface. Allow the primer to dry thoroughly. This is usually accomplished in 5 minutes at room temperature. Be sure the primed surface remains free from contaminants.
5. Return the housing to the vehicle and connect the strobe/halogen cables to their respective lighthoods. Remember that the cables must be connected correctly or the system will not function properly.
6. Locate the ends of the adhesive tape strips indicated below. Peel approximately an inch of the protective backing away from the tape. Now fold the backing so that it sticks out from under the FastTrax housing.

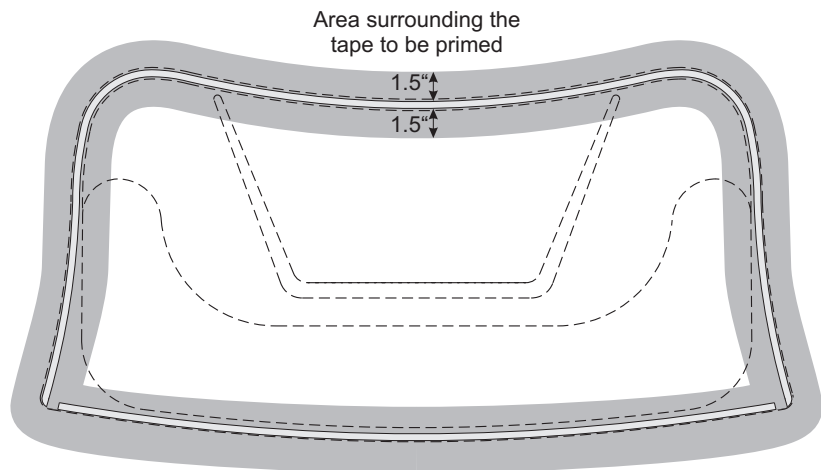

7. Carefully pull the protective backing tabs out from under the FastTrax housing. Make sure that the housing's position is not disturbed during this process.

8. With all of the protective backing strips removed, press down firmly along the edges of the housing to promote adhesion.

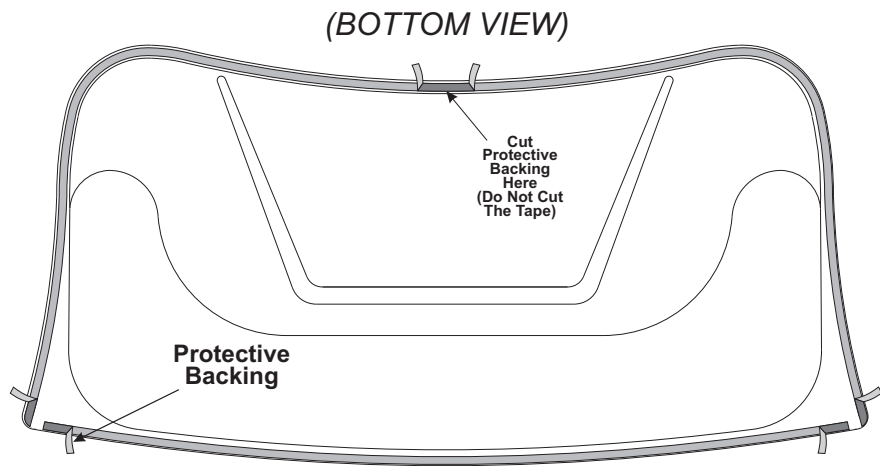

WARNING! The vehicle should not be driven for a minimum of 24 hours after installation. The adhesive used in this procedure must remain at 65°F (minimum) for 24 hours after installation. Caution should be used if the vehicle must be driven between 24 and 72 hours after installation. The adhesive should be fully bonded after 72 hours.

Mounting the FastTrax™ Control Head...

1. Locate a suitable mounting location for the control head. Be sure that the control head fits properly and does not interfere with any dashboard components.

WARNING! *If the vehicle is equipped with air bags, do not mount the control head within the "air bag deployment zone(s)" indicated in the vehicle owner's manual. Failure to heed this warning could impair the air bag's ability to function properly which could, in the event of deployment, result in serious injury or death!*

2. Position the control head on the proposed mounting location. Using a pencil or other suitable tool, scribe the mounting surface where the holes are to be drilled.

CAUTION! *As mounting the control head will require drilling, it is absolutely necessary to make sure that no vehicle components could be damaged by the mounting process. Check both sides of the mounting surface before starting and if damage is possible, select a different mounting location.*

3. Drill the 2 mounting screw holes.

4. Position the control head onto the mounting surface. Using the provided sheet metal screws, secure the control head to the mounting surface.

5. Route the 9-conductor control harness and the modular Diagnostix cable from the control head to the power supply. These cables may be plugged into the control head, but do not plug them into the power supply at this time.

6. Locate the AMP 9-conductor pin housing. Cut and remove the locking tabs from this housing as shown.

7. Using this illustration, insert the pinned wires on the control harness into their proper location in the pin housing and plug this cable into its port on the power supply.

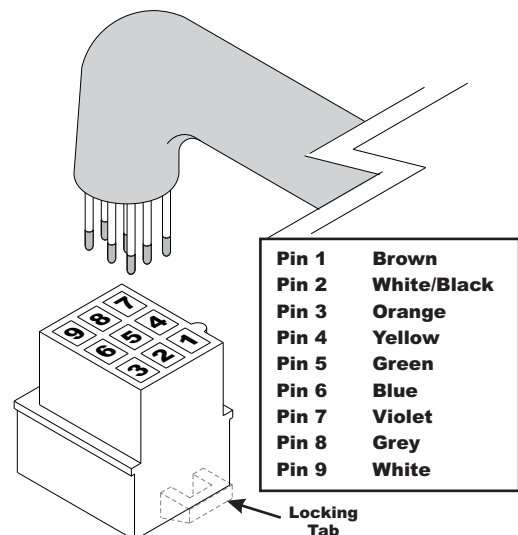

A Note On Painting the FastTrax Housing...

If painting or re-painting your FastTrax™ housing, it is important to keep in mind the following information:

- Do not apply paint or primer to any of the black-colored area immediately adjacent to the clear outer lens!
- Do not apply paint or primer to the underside of the housing.
- Make sure that all surfaces to be painted have been primed using primer that is suitable for ABS plastic.
- Be sure to include the leading edges (material thickness) in your painting surfaces.

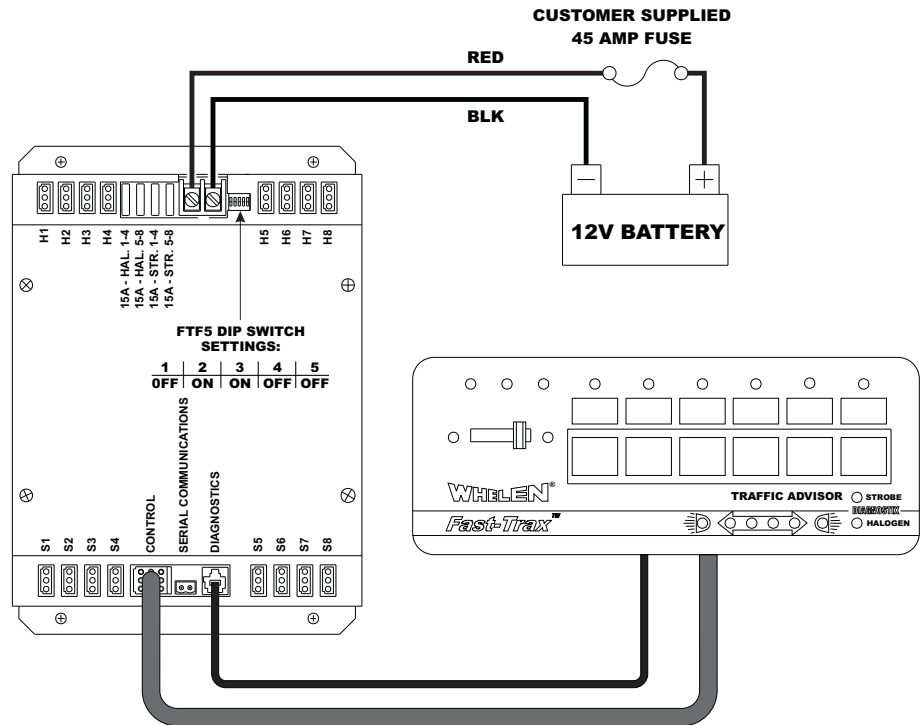

STROBE SPECIFICATIONS

INPUT VOLTAGE	-----	12.8 VDC ± 20%
INPUT CURRENT		
2 STROBES	-----	4.5 AMPS (TYP)
4 STROBES	-----	9 AMPS (TYP)
6 STROBES	-----	13.5 AMPS (TYP)
8 STROBES	-----	18 AMPS (TYP)
INPUT POWER	-----	230 WATTS (TYP)
ANODE VOLTAGE	-----	450 VDC (MAX)
TRIG. VOLTAGE	-----	150 VDC (MIN)
ENERGY PER FLASH	-----	7.9 / 3.8 / 3.8 / 3.8
FLASHRATE	-----	140 CFPM
OUTPUT POWER	-----	22.5 WATTS (TYP)
(PER OUTLET)		

HALOGEN SPECIFICATIONS

INPUT VOLTAGE	-----	12.8 VDC ± 20%
INPUT CURRENT		
2 LAMPS	-----	4.5 AMPS (TYP)
INPUT POWER	-----	230 WATTS (TYP)
OUTPUT VOLTAGE	-----	INPUT VOLTAGE - 1V
ON TIME	-----	125 mS (TYP)
OFF TIME	-----	125 mS (TYP)
FLASHRATE	-----	120 DFPM ±5%
OUTPUT POWER	-----	50 WATTS (MAX)
(PER OUTLET)		

Model FTF5

**Push-Button 1 Control Table
Model FTF5 Only**

Push-Button 1	Effect
OFF	None
ON	T-D (H5 & H8) On

Push-Buttons 2&3 Control Table

Push-Button 2	Push-Button 3	Flash Pattern
OFF	OFF	Comet Flash (Default)
ON	OFF	Double Flash
OFF	ON	Rapid Rate
ON	ON	Action Flash

**Push-Button 4 Control Table
Not Used**

**Push-Button 4 Control Table
Not Used**

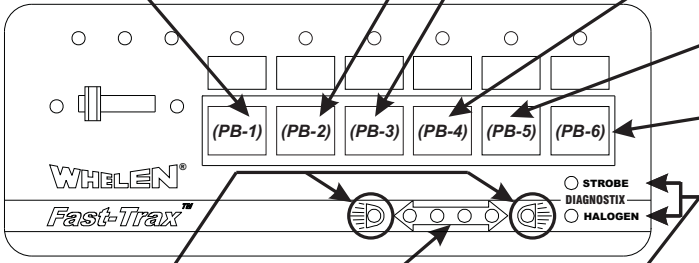

Push-Button 6 Control Table

Push-Button 6	Effect
PUSH #1	Hi Power Mode
PUSH #2	Lo Power Mode

Not Used

Not Used

Diagnostix LED Indicators

**Slide Switch Table
Model FTF5
(In Default Dip Switch Positions)**

	Strobes S1 + S4	Strobes S2 + S3	Strobes S5 + S8	Strobes S6 + S7	Halogens H5 + H8
Off	X	X	X	X	X
Position 1	X	ON	X	ON	X
Position 2	ON	ON	X	ON	X
Position 3	ON	ON	ON	ON	ON

NOTE: "X" = OFF

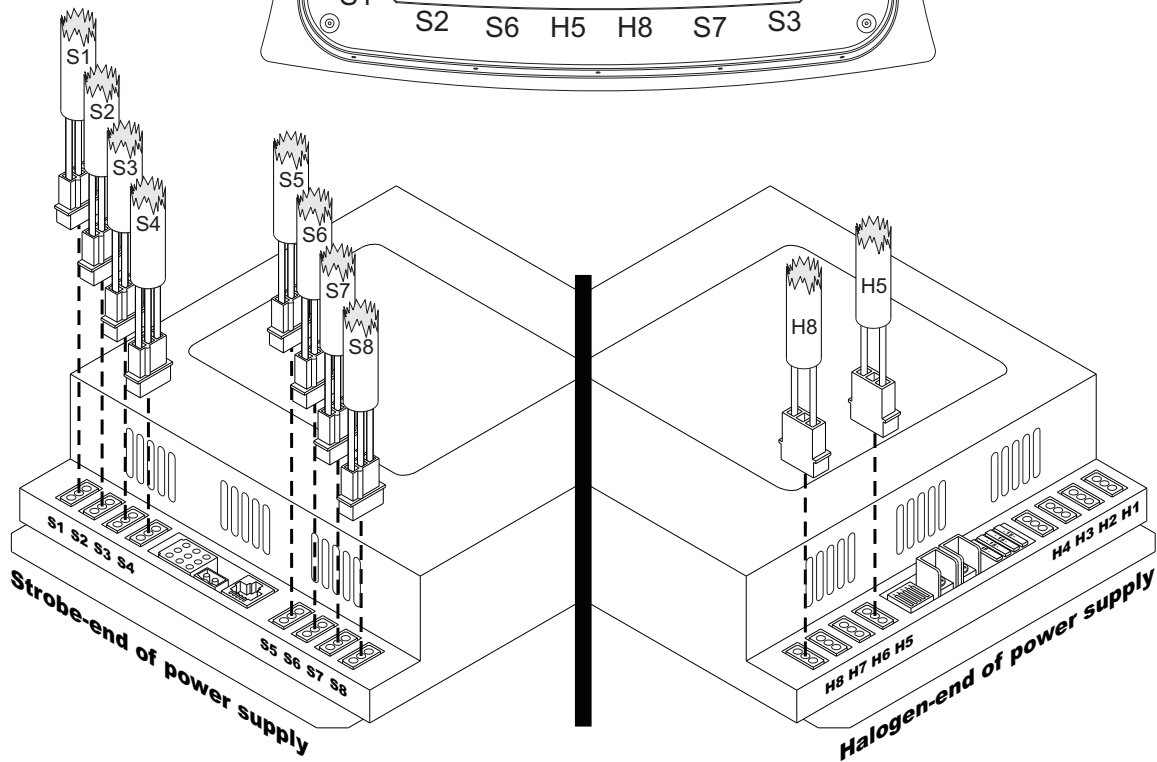
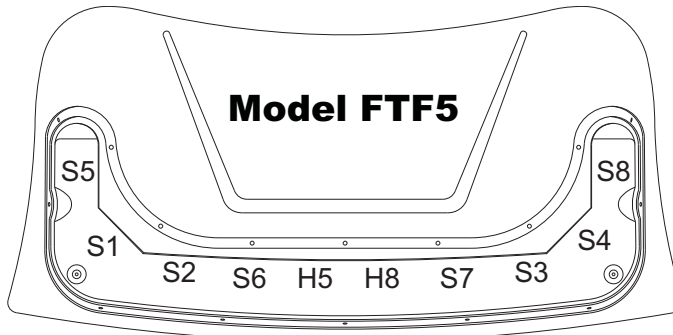

Not Shown
Not Shown
Not Shown

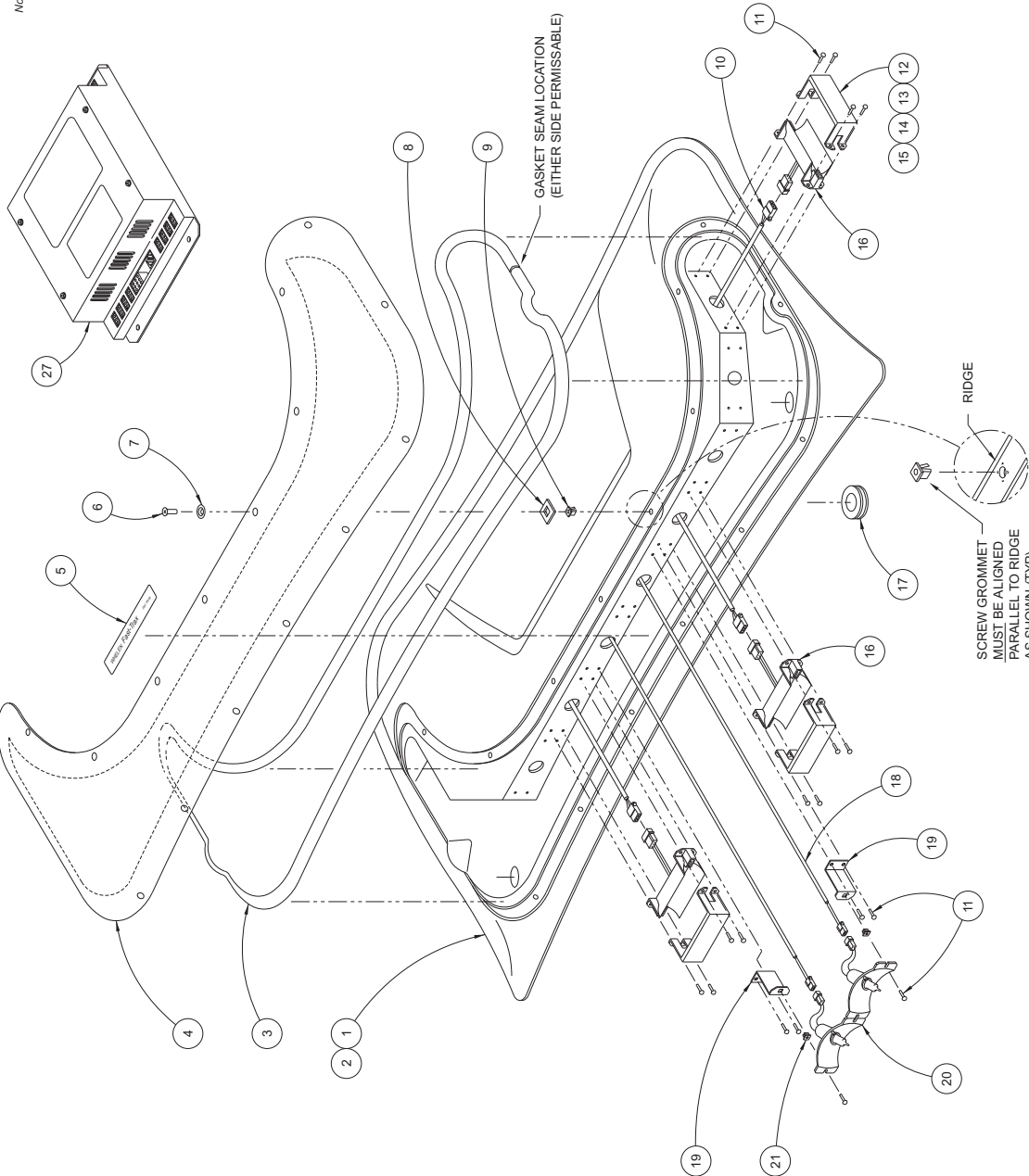

QTY.	ITEM	PART NUMBER	DESCRIPTION
1	27	01-0683216-00	ELECTRONIC ASSY MODEL ISPRHS
1	1	10-0742600-02	LABEL, CABLE I.D.
10	10	01-0415532-00	KIT, CABLE INSTALLATION (3 POS.)
01	01	66-0110008-00	ISOPROPYL ALCOHOL (CLEANER)
2	2	66-0716725-00	"3M" #84 PRIMER APPLICATOR
A/R	A/R	66-0416676-00	TAPE, "VHB" DOUBLE STICK (BLACK)
2	2	13-062C00-16J	#6 SCREW GROMMET #242-16002/70
1	1	02-0342292-01	ASSY, REFLECTOR DUAL HALOGEN 12V/27H
2	2	19 07-242665-000	BRACKET, DUAL HALOGEN MOUNT
2	2	18 46-0742574-20	ASSY, CABLE 2/C AUTO EXTENSION 20"
2	2	17 21-11263204-0	GROMMET, 1"
8	8	16 02-0353043-00	ASSY, REFLECTOR 14 SERIES STROBE
A/R	A/R	15 68-3162885-50	LENS, 14 SERIES (RED)
A/R	A/R	14 68-3162885-40	LENS, 14 SERIES (GREEN)
A/R	A/R	13 68-3162885-20	LENS, 14 SERIES (BLUE)
A/R	A/R	12 68-3162885-10	LENS, 14 SERIES (AMBER)
42	42	11 15-065419-080	#6 X 1/2" PPH PLAST-LOC SCREW
8	8	10 46-0702172-20	ASSY, CABLE 3/C AUTO EXTENSION 20"
17	17	9 21-12060905-1	#6 SCREW GROMMET
17	17	8 38-0122685-00	GASKET, SCREW GROMMET
17	17	7 16-06A192A-25	#6 CSK WASHER SS (BLACK PHOSPHATE)
17	17	6 15-081218-106	#6 X 5/8" PFHMS 100E (BLACK ZINC OXIDE)
1	1	5 10-0322594-02	LABEL, REGISTERED TRADE MARK
1	1	4 68-3183242-31	LENS, NON OPTIC (CLEAR)
A/R	A/R	3 38-0522686-00	GASKET, "D" SHAPE W/PSA
1	-	2 11-483241-001	HOUSING, (PAINTED)
-	1	1 11-483241-000	HOUSING, (AS MOLDED)
*	*	01-0683334-01	ASSY, 8 STROBE-0 HAL. (PAINTED)
*	*	01-0683334-00	ASSY, 8 STROBE-0 HAL. (RAW)

© 1998, COPYRIGHT, WHEELER ENGINEERING COMPANY
Fast-Trax™
Model FTF5
1998 Ford Crown Victoria

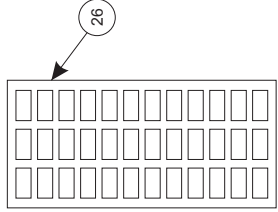

The outer surfaces of this product may be cleaned with mild soap and water. Use of any other chemicals may void product warranty. Do not use a pressure washer.