

### Warnings to Installers

Whelen's emergency vehicle warning devices must be properly mounted and wired in order to be effective and safe. Read and follow all of Whelen's written instructions when installing or using this device. Emergency vehicles are often operated under high speed stressful conditions which must be accounted for when installing all emergency warning devices. Controls should be placed within convenient reach of the operator so that they can operate the system without taking their eyes off the roadway. Emergency warning devices can require high electrical voltages and/or currents. Properly protect and use caution around live electrical connections. Grounding or shorting of electrical connections can cause high current arcing, which can cause personal injury and/or vehicle damage, including fire. Many electronic devices used in emergency vehicles can create or be affected by electromagnetic interference. Therefore, after installation of any electronic device it is necessary to test all electronic equipment simultaneously to insure that they operate free of interference from other components within the vehicle. Never power emergency warning equipment from the same circuit or share the same grounding circuit with radio communication equipment. All devices should be mounted in accordance with the manufacturer's instructions and securely fastened to vehicle elements of sufficient strength to withstand the forces applied to the device. Driver and/or passenger air bags (SRS) will affect the way equipment should be mounted. This device should be mounted by permanent installation and within the zones specified by the vehicle manufacturer, if any. Any device mounted in the deployment area of an air bag will damage or reduce the effectiveness of the air bag and may damage or dislodge the device. Installer must be sure that this device, its mounting hardware and electrical supply wiring does not interfere with the air bag or the SRS wiring or sensors. Mounting the unit inside the vehicle by a method other than permanent installation is not recommended as unit may become dislodged during swerving; sudden braking or collision. Failure to follow instructions can result in personal injury. Whelen assumes no liability for any loss resulting from the use of this warning device. **PROPER INSTALLATION COMBINED WITH OPERATOR TRAINING IN THE PROPER USE OF EMERGENCY WARNING DEVICES IS ESSENTIAL TO INSURE THE SAFETY OF EMERGENCY PERSONNEL AND THE PUBLIC.**

### Warnings to Users

Whelen's emergency vehicle warning devices are intended to alert other operators and pedestrians to the presence and operation of emergency vehicles and personnel. However, the use of this or any other Whelen emergency warning device does not guarantee that you will have the right-of-way or that other drivers and pedestrians will properly heed an emergency warning signal. Never assume you have the right-of-way. It is your responsibility to proceed safely before entering an intersection, driving against traffic, responding at a high rate of speed, or walking on or around traffic lanes. Emergency vehicle warning devices should be tested on a daily basis to ensure that they operate properly. When in actual use, the operator must ensure that both visual and audible warnings are not blocked by vehicle components (i.e.: open trunks or compartment doors), people, vehicles, or other obstructions. It is the user's responsibility to understand and obey all laws regarding emergency warning devices. The user should be familiar with all applicable laws and regulations prior to the use of any emergency vehicle warning device. Whelen's audible warning devices are designed to project sound in a forward direction away from the vehicle occupants. However, because sustained periodic exposure to loud sounds can cause hearing loss, all audible warning devices should be installed and operated in accordance with the standards established by the National Fire Protection Association.

### Safety First

This document provides all the necessary information to allow your Whelen product to be properly and safely installed. Before beginning the installation and/or operation of your new product, the installation technician and operator must read this manual completely. Important information is contained herein that could prevent serious injury or damage.

**⚠ WARNING:** This product can expose you to chemicals including Methylene Chloride which is known to the State of California to cause cancer, and Bisphenol A, which is known to the State of California to cause birth defects or other reproductive harm. For more information go to [www.P65Warnings.ca.gov](http://www.P65Warnings.ca.gov).

- **Proper installation of this product requires the installer to have a good understanding of automotive electronics, systems and procedures.**
- **Whelen Engineering requires the use of waterproof butt splices and/or connectors if that connector could be exposed to moisture.**
- **Any holes, either created or utilized by this product, should be made both air- and watertight using a sealant recommended by your vehicle manufacturer.**
- **Failure to use specified installation parts and/or hardware will void the product warranty.**
- **If mounting this product requires drilling holes, the installer MUST be sure that no vehicle components or other vital parts could be damaged by the drilling process. Check both sides of the mounting surface before drilling begins. Also de-burr the holes and remove any metal shards or remnants. Install grommets into all wire passage holes.**
- **If this manual states that this product may be mounted with suction cups, magnets, tape or Velcro<sup>®</sup>, clean the mounting surface with a 50/50 mix of isopropyl alcohol and water and dry thoroughly.**
- **Do not install this product or route any wires in the deployment area of your air bag. Equipment mounted or located in the air bag deployment area will damage or reduce the effectiveness of the air bag, or become a projectile that could cause serious personal injury or death. Refer to your vehicle owner's manual for the air bag deployment area. The User/Installer assumes full responsibility to determine proper mounting location, based on providing ultimate safety to all passengers inside the vehicle.**
- **For this product to operate at optimum efficiency, a good electrical connection to chassis ground must be made. The recommended procedure requires the product ground wire to be connected directly to the NEGATIVE (-) battery post (this does not include products that use cigar power cords).**
- **If this product uses a remote device for activation or control, make sure that this device is located in an area that allows both the vehicle and the device to be operated safely in any driving condition.**
- **Do not attempt to activate or control this device in a hazardous driving situation.**
- **This product contains either strobe light(s), halogen light(s), high-intensity LEDs or a combination of these lights. Do not stare directly into these lights. Momentary blindness and/or eye damage could result.**
- **Use only soap and water to clean the outer lens. Use of other chemicals could result in premature lens cracking (crazing) and discoloration. Lenses in this condition have significantly reduced effectiveness and should be replaced immediately. Inspect and operate this product regularly to confirm its proper operation and mounting condition. Do not use a pressure washer to clean this product.**
- **It is recommended that these instructions be stored in a safe place and referred to when performing maintenance and/or reinstallation of this product.**
- **FAILURE TO FOLLOW THESE SAFETY PRECAUTIONS AND INSTRUCTIONS COULD RESULT IN DAMAGE TO THE PRODUCT OR VEHICLE AND/OR SERIOUS INJURY TO YOU AND YOUR PASSENGERS!**



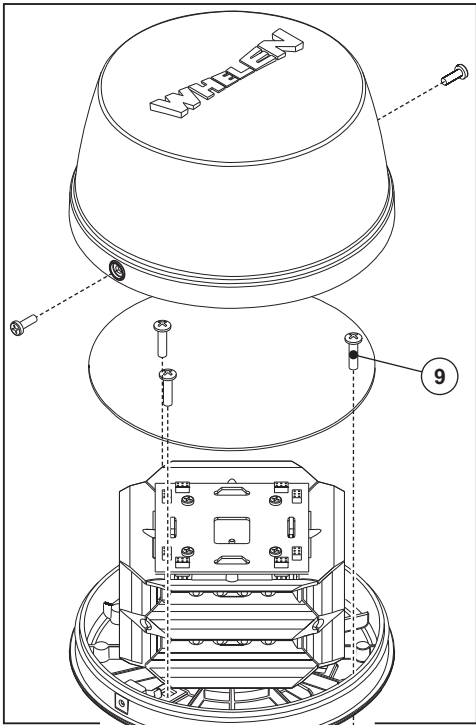

**Specifications**

**Input Voltage:** 12.8 VDC ±20  
**Input Current:** L360 Beacon - 1.5 AMPS  
**Input Current:** 700 Flasher - .75 AMPS  
**Flash Patterns:** SignalAlert™ (Default)  
**Low Power:** +12V Active

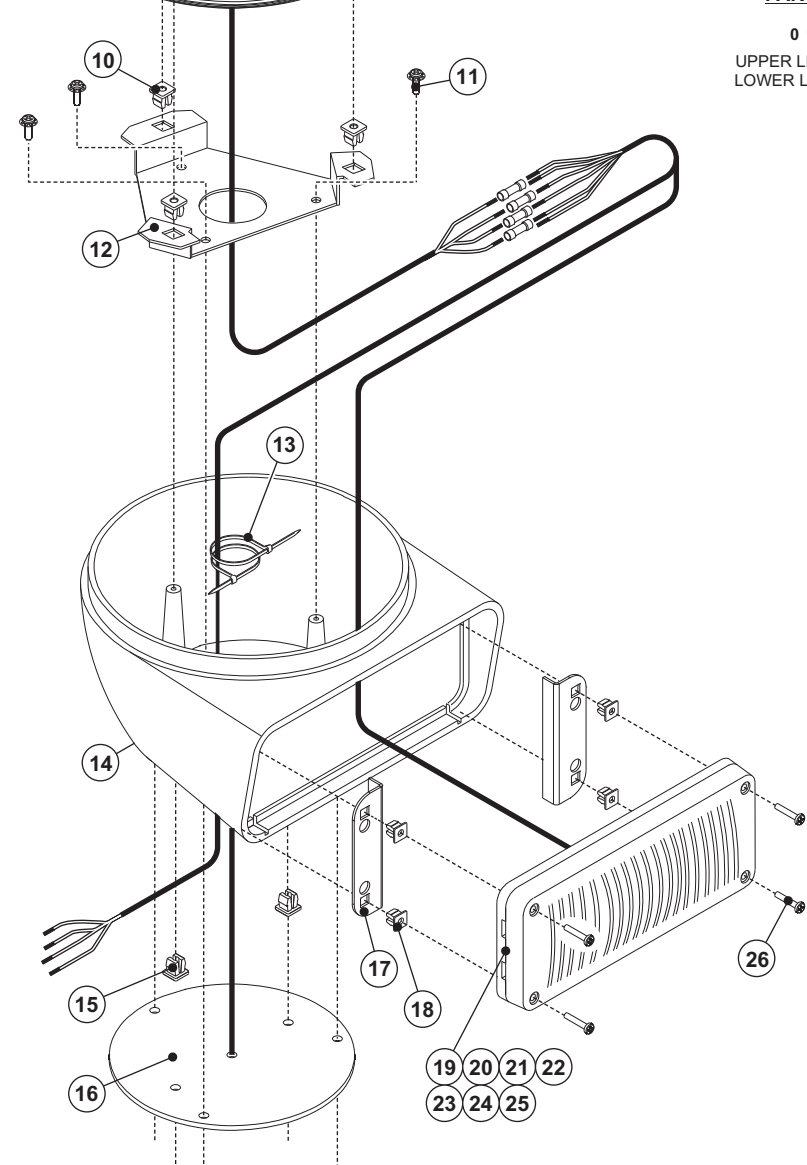
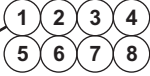

QTY	ITEM	PART NUMBER	DESCRIPTION
*		01-0684139-__	B6MM SERIES Super-LED® L360 / 700 LED
A/R	1	01-0685953-AF	BEACON AMB/AMB FLAT MT L360 SERIES
A/R	2	01-0685953-BF	BEACON BLU-BLU FLAT MT L360 SERIES
A/R	3	01-0685953NRF	BEACON RED-RED NFPA FLAT MT L360 SERIES
A/R	4	01-0685953-1F	BEACON AMB-CLR FLAT MT L360 SERIES
A/R	5	01-0685953-2F	BEACON BLU-CLR FLAT MT L360 SERIES
A/R	6	01-0685953-3F	BEACON WHT-CLR FLAT MT L360 SERIES
A/R	7	01-0685953N5F	BEACON RED-CLR NFPA FLAT MT L360 SERIES
A/R	8	01-0685953-GF	BEACON GREEN/GREEN FLAT MT L360 SERIES
3	9	15-101416-120	SCREW / #10 X 3/4" PPHSMS SS
3	10	21-17060704-3	SCREW GROMMET FASTEX
3	11	14-062216-061	SCREW / #6-32 X 3/8" PPHMS SEMS
1	12	07-263938-000	BRACKET / MOUNTING B6R MECHANISM 360° LED
2	13	26-0215001-06	TY-WRAP / 6" BLACK
1	14	11-483144-011	HOUSING / BASE MODEL B6R - POLISHED
REF	15	21-12081205-3	SCREW GROMMET FASTEX
REF	16	38-0242422-00	GASKET / MOUNTING B6R SERIES
2	17	07-242837-000	BRACKET / MOUNTING MECHANISM / LOWER LED
4	18	13-062C40-16J	#6 - #8 SCREW GROMMET
A/R	19	01-0286419410	700 LINEAR TIR / AMBER-CLEAR
A/R	20	01-0286419420	700 LINEAR TIR / BLUE-CLEAR
A/R	21	01-0286419430	700 LINEAR TIR / WHITE-CLEAR
A/R	22	01-0286419450	700 LINEAR TIR / RED-CLEAR
A/R	23	01-02864194A0	700 LINEAR TIR / AMBER-AMBER
A/R	24	01-02864194B0	700 LINEAR TIR / BLUE-BLUE
A/R	25	01-02864194R0	700 LINEAR TIR / RED-RED
4	26	15-061416-240	SCREW / #6 X 1 1/2" PPHSMS

**PART NUMBER KEY:**

**UPPER LED / LENS COLOR**

**LOWER LED / LENS COLOR**

**0 1 - 0 6 8 4 1 3 9 -**  
UPPER LED / LENS COLOR }  
LOWER LED / LENS COLOR }

A = AMBER / AMBER	A = AMBER / AMBER
B = BLUE / BLUE	B = BLUE / BLUE
R = RED / RED	R = RED / RED
1 = AMBER / CLEAR	1 = AMBER / CLEAR
2 = BLUE / CLEAR	2 = BLUE / CLEAR
3 = WHITE / CLEAR	3 = WHITE / CLEAR
5 = RED / CLEAR	5 = RED / CLEAR
G = GRN / GRN	

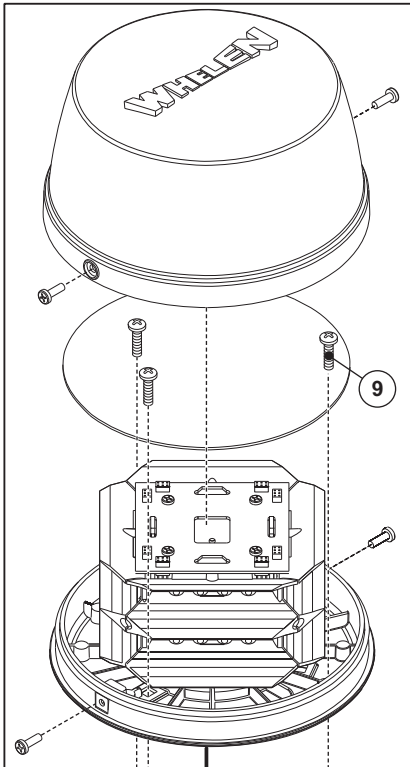

**Specifications**  
**Input Voltage:** 12.8 VDC ±20  
**Input Current:** L360 Beacon - 1.5 AMPS  
**Input Current:** 700 Flasher - .75 AMPS  
**Flash Patterns:** SignalAlert™ (Default)  
**Low Power:** +12V Active

- 1 2
- 3 4
- 5 6
- 7 8

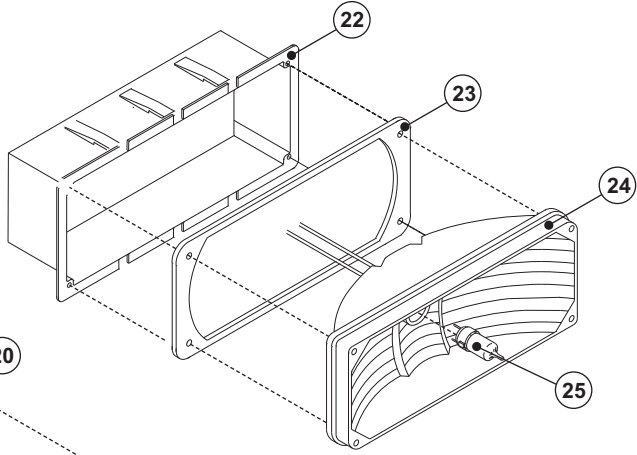
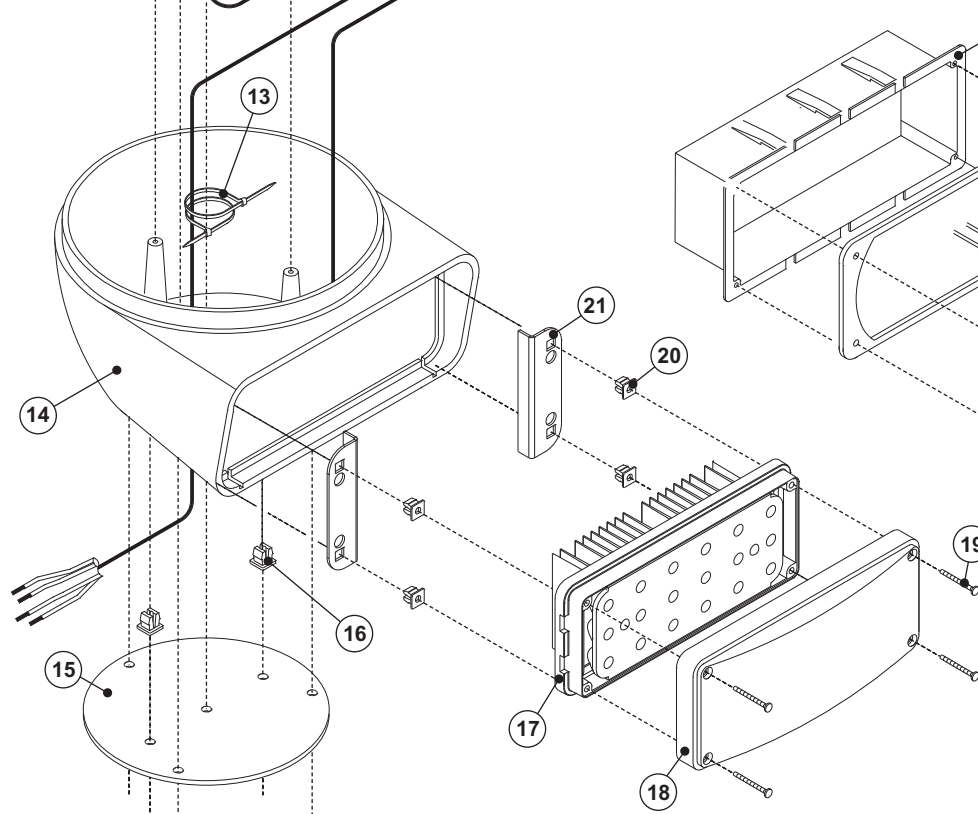
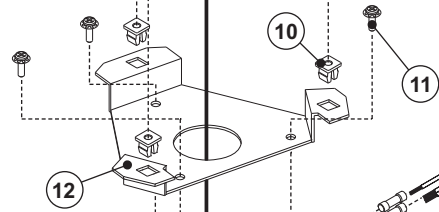

QTY	QTY	ITEM	PART NUMBER	DESCRIPTION
*	*		01-0684139-_Y	B6MM SERIES Super-LED L360/LED SCENE
*	*		01-0684139-_Z	B6MM SERIES Super-LED L360/HALO SCENE
A/R	A/R	1	01-0685953-AF	BEACON AMB/AMB FLAT MT L360 SERIES
A/R	A/R	2	01-0685953-BF	BEACON BLU/BLU FLAT MT L360 SERIES
A/R	A/R	3	01-0685953NRF	BEACON RED/RED NFPA FLAT MT L360 SERIES
A/R	A/R	4	01-0685953-1F	BEACON AMB/CLR FLAT MT L360 SERIES
A/R	A/R	5	01-0685953-2F	BEACON BLU/CLR FLAT MT L360 SERIES
A/R	A/R	6	01-0685953-3F	BEACON WHT/CLR FLAT MT L360 SERIES
A/R	A/R	7	01-0685953N5F	BEACON RED/CLR NFPA FLAT MT L360 SERIES
A/R	A/R	8	01-0685953-GF	ASSY / BEACON GRN/GRN FLAT MT L360 SERIES
3	3	9	15-101416-120	SCREW / #10 X 3/4" PPHSMS SS
3	3	10	21-17060704-3	SCREW GROMMET FASTEX
3	3	11	14-062216-061	SCREW / #6-32 X 3/8" PPHSMS SEMS
1	1	12	07-263938-000	BRACKET / MOUNTING B6R MECHANISM 360° LED
2	2	13	26-0215001-06	TY-WRAP / 6" BLACK
1	1	14	11-483144-011	HOUSING / BASE MODEL B6R - POLISHED
REF	REF	15	38-0242422-00	GASKET / MOUNTING B6R SERIES
REF	REF	16	21-12081205-3	SCREW GROMMET FASTEX
-	A/R	17	01-026A532-10	SUB-ASS'Y / LED SCENE LT 700 / NO CONNECTOR
1	1	18	68-1183464-3S	LENS / CLEAR 7E SCENELIGHT W/ SEAL
4	4	19	15-061416-240	SCREW / #6 X 1 1/2" PPHSMS
-	4	20	13-062C40-16J	SCREW GROMMET / #6/8
-	2	21	07-242837-000	BRACKET / MOUNTING MECHANISM / LOWER LED
1	-	22	11-461065-000	HOUSING / LIGHT ASSY MINI MAX
1	-	23	38-0241199-00	GASKET
1	-	24	02-0383709-05	700 REFLECTOR W/O LAMP 2-WIRE NO CONN
1	-	25	34-0041987-00	SNAP-IN LAMP 12V/35H

**01-0684139-**  
**UPPER LED / LENS COLOR**  
**LOWER SCENE STYLE**

**UPPER LED / LENS COLOR**  
**A** = AMBER / AMBER      **2** = BLUE / CLEAR  
**B** = BLUE / BLUE        **3** = WHITE / CLEAR  
**R** = RED / RED            **5** = RED / CLEAR  
**1** = AMBER / CLEAR       **G** = GRN / GRN

**LOWER SCENE STYLE**  
**Z** = HALOGEN SCENE  
**Y** = LED SCENE

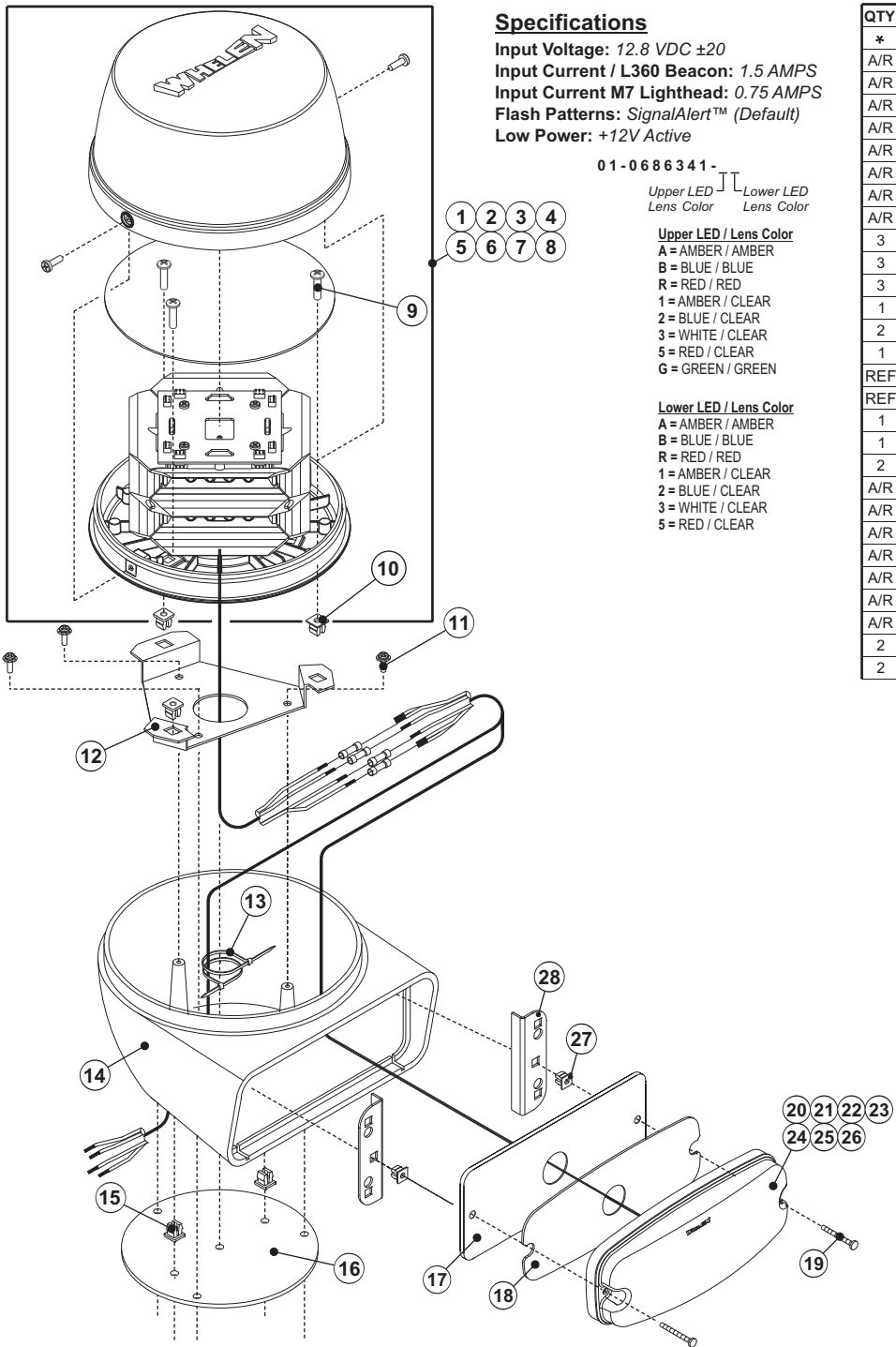

**Specifications**

**Input Voltage:** 12.8 VDC ±20  
**Input Current / L360 Beacon:** 1.5 AMPS  
**Input Current M7 Lighthouse:** 0.75 AMPS  
**Flash Patterns:** SignalAlert™ (Default)  
**Low Power:** +12V Active

01-0686341-

Upper LED Lens Color | Lower LED Lens Color

**Upper LED / Lens Color**

- A = AMBER / AMBER
- B = BLUE / BLUE
- R = RED / RED
- 1 = AMBER / CLEAR
- 2 = BLUE / CLEAR
- 3 = WHITE / CLEAR
- 5 = RED / CLEAR
- G = GREEN / GREEN

**Lower LED / Lens Color**

- A = AMBER / AMBER
- B = BLUE / BLUE
- R = RED / RED
- 1 = AMBER / CLEAR
- 2 = BLUE / CLEAR
- 3 = WHITE / CLEAR
- 5 = RED / CLEAR

QTY	ITEM	PART NUMBER	DESCRIPTION
*		01-0686341-__	B6M7 SERIES Super-LED L360/M7 LED
A/R	1	01-0685953-AF	BEACON AMB-AMB FLAT MT L360 SERIES
A/R	2	01-0685953-BF	BEACON BLU-BLU FLAT MT L360 SERIES
A/R	3	01-0685953NRF	BEACON RED-RED NFPA FLAT MT L360 SERIES
A/R	4	01-0685953-1F	BEACON AMB-CLR FLAT MT L360 SERIES
A/R	5	01-0685953-2F	BEACON BLU-CLR FLAT MT L360 SERIES
A/R	6	01-0685953-3F	BEACON WHT-CLR FLAT MT L360 SERIES
A/R	7	01-0685953N5F	BEACON RED/CLR NFPA FLAT MT L360 SERIES
A/R	8	01-0685953-GF	BEACON GRN-GRN FLAT MT L360 SERIES
3	9	15-101416-120	SCREW / #10 X 3/4" PPHSMS SS
3	10	21-17060704-3	SCREW GROMMET FASTEX
3	11	14-062216-061	SCREW / #6-32 X 3/8" PPHSMS SEMS
1	12	07-263938-000	BRACKET / MTG B6MM MECHANISM 360° LED
2	13	26-0215001-06	TY-WRAP / 6" BLACK
1	14	11-483144-011	HOUSING / BASE MODEL B6R - POLISHED
REF	15	21-12081205-3	SCREW GROMMET FASTEX
REF	16	38-0242422-00	GASKET / MOUNTING B6R SERIES
1	17	07-743879-000	M7 TO B6R-B6T ADAPTOR PLATE
1	18	38-0143750-00	GASKET / DIE CUT PSA M7
2	19	15-081416-160	SCREW / #8 X 1" PPHSMS
A/R	20	02-036A796-A0	SUB ASSY / M7 SYNC AMB-AMB
A/R	21	02-036A796-B0	SUB ASSY / M7 SYNC BLU-BLU
A/R	22	02-036A796-30	SUB ASSY / M7 SYNC WHT-CLR
A/R	23	02-036A796-R0	SUB ASSY / M7 SYNC RED-RED
A/R	24	02-036A796-10	SUB ASSY / M7 SYNC AMB-CLR
A/R	25	02-036A796-20	SUB ASSY / M7 SYNC BLU-CLR
A/R	26	02-036A796-50	SUB ASSY / M7 SYNC RED-CLR
2	27	13-062C40-16J	SCREW GROMMET #6/8
2	28	07-242837-000	BRACKET / MOUNTING LED B6R