

WHELEN[®]

ENGINEERING COMPANY INC.

51 Winthrop Road
Chester, Connecticut 06412-0684
Phone: (860) 526-9504
Internet: www.whelen.com
Sales e-mail: autosale@whelen.com
Customer Service e-mail: custserv@whelen.com

Installation Guide:
500 Series Linear Super-LED[®] Lighthead

Warnings to Installers

Whelen's emergency vehicle warning devices must be properly mounted and wired in order to be effective and safe. Read and follow all of Whelen's written instructions when installing or using this device. Emergency vehicles are often operated under high speed stressful conditions which must be accounted for when installing all emergency warning devices. Controls should be placed within convenient reach of the operator so that they can operate the system without taking their eyes off the roadway. Emergency warning devices can require high electrical voltages and/or currents. Properly protect and use caution around live electrical connections. Grounding or shorting of electrical connections can cause high current arcing, which can cause personal injury and/or vehicle damage, including fire. Many electronic devices used in emergency vehicles can create or be affected by electromagnetic interference. Therefore, after installation of any electronic device it is necessary to test all electronic equipment simultaneously to insure that they operate free of interference from other components within the vehicle. Never power emergency warning equipment from the same circuit or share the same grounding circuit with radio communication equipment. All devices should be mounted in accordance with the manufacturer's instructions and securely fastened to vehicle elements of sufficient strength to withstand the forces applied to the device. Driver and/or passenger air bags (SRS) will affect the way equipment should be mounted. This device should be mounted by permanent installation and within the zones specified by the vehicle manufacturer, if any. Any device mounted in the deployment area of an air bag will damage or reduce the effectiveness of the air bag and may damage or dislodge the device. Installer must be sure that this device, its mounting hardware and electrical supply wiring does not interfere with the air bag or the SRS wiring or sensors. Mounting the unit inside the vehicle by a method other than permanent installation is not recommended as unit may become dislodged during swerving; sudden braking or collision. Failure to follow instructions can result in personal injury. Whelen assumes no liability for any loss resulting from the use of this warning device. **PROPER INSTALLATION COMBINED WITH OPERATOR TRAINING IN THE PROPER USE OF EMERGENCY WARNING DEVICES IS ESSENTIAL TO INSURE THE SAFETY OF EMERGENCY PERSONNEL AND THE PUBLIC.**

Warnings to Users

Whelen's emergency vehicle warning devices are intended to alert other operators and pedestrians to the presence and operation of emergency vehicles and personnel. However, the use of this or any other Whelen emergency warning device does not guarantee that you will have the right-of-way or that other drivers and pedestrians will properly heed an emergency warning signal. Never assume you have the right-of-way. It is your responsibility to proceed safely before entering an intersection, driving against traffic, responding at a high rate of speed, or walking on or around traffic lanes. Emergency vehicle warning devices should be tested on a daily basis to ensure that they operate properly. When in actual use, the operator must ensure that both visual and audible warnings are not blocked by vehicle components (i.e.: open trunks or compartment doors), people, vehicles, or other obstructions. It is the user's responsibility to understand and obey all laws regarding emergency warning devices. The user should be familiar with all applicable laws and regulations prior to the use of any emergency vehicle warning device. Whelen's audible warning devices are designed to project sound in a forward direction away from the vehicle occupants. However, because sustained periodic exposure to loud sounds can cause hearing loss, all audible warning devices should be installed and operated in accordance with the standards established by the National Fire Protection Association.

Safety First

This document provides all the necessary information to allow your Whelen product to be properly and safely installed. Before beginning the installation and/or operation of your new product, the installation technician and operator must read this manual completely. Important information is contained herein that could prevent serious injury or damage.

⚠ WARNING: This product can expose you to chemicals including Methylene Chloride which is known to the State of California to cause cancer, and Bisphenol A, which is known to the State of California to cause birth defects or other reproductive harm. For more information go to www.P65Warnings.ca.gov.

- **Proper installation of this product requires the installer to have a good understanding of automotive electronics, systems and procedures.**
- **Whelen Engineering requires the use of waterproof butt splices and/or connectors if that connector could be exposed to moisture.**
- **Any holes, either created or utilized by this product, should be made both air- and watertight using a sealant recommended by your vehicle manufacturer.**
- **Failure to use specified installation parts and/or hardware will void the product warranty.**
- **If mounting this product requires drilling holes, the installer MUST be sure that no vehicle components or other vital parts could be damaged by the drilling process. Check both sides of the mounting surface before drilling begins. Also de-burr the holes and remove any metal shards or remnants. Install grommets into all wire passage holes.**
- **If this manual states that this product may be mounted with suction cups, magnets, tape or Velcro[®], clean the mounting surface with a 50/50 mix of isopropyl alcohol and water and dry thoroughly.**
- **Do not install this product or route any wires in the deployment area of your air bag. Equipment mounted or located in the air bag deployment area will damage or reduce the effectiveness of the air bag, or become a projectile that could cause serious personal injury or death. Refer to your vehicle owner's manual for the air bag deployment area. The User/Installer assumes full responsibility to determine proper mounting location, based on providing ultimate safety to all passengers inside the vehicle.**
- **For this product to operate at optimum efficiency, a good electrical connection to chassis ground must be made. The recommended procedure requires the product ground wire to be connected directly to the NEGATIVE (-) battery post (this does not include products that use cigar power cords).**
- **If this product uses a remote device for activation or control, make sure that this device is located in an area that allows both the vehicle and the device to be operated safely in any driving condition.**
- **Do not attempt to activate or control this device in a hazardous driving situation.**
- **This product contains either strobe light(s), halogen light(s), high-intensity LEDs or a combination of these lights. Do not stare directly into these lights. Momentary blindness and/or eye damage could result.**
- **Use only soap and water to clean the outer lens. Use of other chemicals could result in premature lens cracking (crazing) and discoloration. Lenses in this condition have significantly reduced effectiveness and should be replaced immediately. Inspect and operate this product regularly to confirm its proper operation and mounting condition. Do not use a pressure washer to clean this product.**
- **It is recommended that these instructions be stored in a safe place and referred to when performing maintenance and/or reinstallation of this product.**
- **FAILURE TO FOLLOW THESE SAFETY PRECAUTIONS AND INSTRUCTIONS COULD RESULT IN DAMAGE TO THE PRODUCT OR VEHICLE AND/OR SERIOUS INJURY TO YOU AND YOUR PASSENGERS!**

NOTICE! Prior to installing on any vehicle, check your state motor vehicle codes to confirm that this product complies with any and all state statutes.

Installation: Refer to the diagrams shown for mounting measurements specific to your model.

IMPORTANT: Customer supplied wire must be a minimum of 18 gauge.

5FLANGE* - Mark the mounting and cut out holes onto the mounting surface. Drill the 2 mounting holes to the sizes noted and remove the area that the lighthouse fits into. Thread the wires through the rubber gasket and extend to your power source. Attach the housing to vehicle using the flange and supplied mounting hardware. Extend the wires to your power source.

5TSM* and **5LSMA*** - Mark off the measurements and drill the wire access and mounting holes. Thread the wires through the rubber gasket, through the wire access hole and to your power source. Attach housing to vehicle using supplied mounting hardware and flange. Extend the wires to your power source.

5GROMMET - Mark off the measurements, drill the two 1.25" holes and cut out the center area. Install the rubber grommet. Assemble the flange, lighthouse and adapter then snap this assembly into the grommet. Extend the wires to your power source.

Scan-Lock™: To advance pattern: With the lighthouse active, apply +VBAT to the WHT/VIO wire for less than 1 second. **To cycle to previous patterns:** Apply +VBAT for more than 1 second. **To restore factory default pattern:** Turn off power to the lighthouse. Apply +VBAT to the

WHT/VIO wire while turning the lighthouse on. Continue to apply voltage to the WHT/VIO wire for 5 seconds.

SYNC Operation: Some of the patterns available for the standard SYNC lighthouse are described as being either Phase 1 (PH.1) or Phase 2 (PH.2). These terms define how patterns on lighthouses with their SYNC wires connected relate to each other. Lighthouses configured to display the same Phase of a given pattern (Phase 1 or Phase 2) will flash simultaneously. Lighthouses configured to Phase 2 of a given pattern will alternate with Phase 1 lighthouses.

Split lighthouses have 2 additional phases. Their operation is more easily understood using the following illustration:

Split Lighthouse Operation

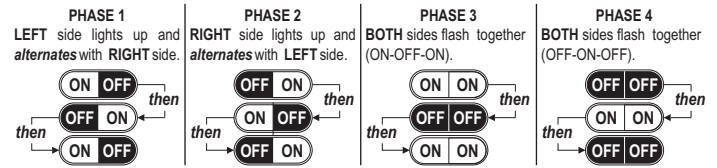

Note: Phases 3 & 4 are visually indistinguishable.

NOTE: The SYNC wire can be connected to other SYNC-capable power supplies to synchronize their output.

Be sure to cap the SYNC wire if it is not used.

IMPORTANT! Before returning the vehicle to active service, visually confirm the proper operation of this product, as well as all vehicle components/equipment.

Wiring

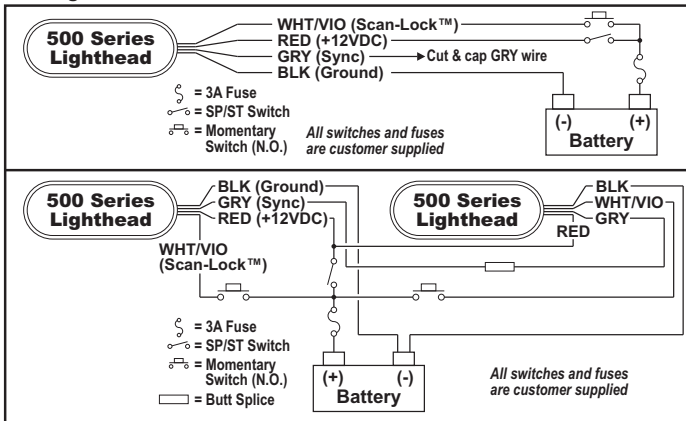

Standard Lighthouse Patterns

- | | | |
|-----------------------------|----------------------------|---------------------|
| 1. SignalAlert™ 75.....PH.1 | 10. ComAlert™ 75.....PH.2 | 19. DoubleFlash 150 |
| 2. SignalAlert™ 75.....PH.2 | 11. LongBurst™ 75.....PH.1 | 20. ComAlert™ 150 |
| 3. CometFlash® 75.....PH.1 | 12. LongBurst™ 75.....PH.2 | 21. ActionFlash™ 1 |
| 4. CometFlash® 75.....PH.2 | 13. PingPong™ 75.....PH.1 | 22. ActionFlash™ 2 |
| 5. DoubleFlash 75.....PH.1 | 14. PingPong™ 75.....PH.2 | 23. ModuFlash™ |
| 6. DoubleFlash 75.....PH.2 | 15. SingleFlash 60 | 24. ActionScan™ |
| 7. SingleFlash 75.....PH.1 | 16. SingleFlash 90 | 25. Steady |
| 8. SingleFlash 75.....PH.2 | 17. SingleFlash 120 | |
| 9. ComAlert™ 75.....PH.1 | 18. SingleFlash 300 | |

NOTE: BOLD = California Title XIII Compliant Pattern *Italic* = SYNC Patterns
NOTE: PHASE 1 ALWAYS ALTERNATES WITH PHASE 2

Split Lighthouse Patterns

- | | | |
|-----------------------------|------------------------------|-----------------------------|
| 1. SignalAlert™ 75.....PH.1 | 25. PingPong™ 75.....PH.1 | 49. DoubleFlash 120.....ALT |
| 2. SignalAlert™ 75.....PH.2 | 26. PingPong™ 75.....PH.2 | 50. DoubleFlash 120.....SIM |
| 3. SignalAlert™ 75.....PH.3 | 27. PingPong™ 75.....PH.3 | 51. PingPong 120.....ALT |
| 4. SignalAlert™ 75.....PH.4 | 28. PingPong™ 75.....PH.4 | 52. PingPong 120.....SIM |
| 5. CometFlash® 75.....PH.1 | 29. SSNF 75.....PH.1 | 53. TripleFlash™ 75.....ALT |
| 6. CometFlash® 75.....PH.2 | 30. SSNF 75.....PH.2 | 54. TripleFlash 75.....SIM |
| 7. CometFlash 75.....PH.3 | 31. SingleFlash 60.....ALT | 55. TripleFlash 120.....ALT |
| 8. CometFlash 75.....PH.4 | 32. SingleFlash 60.....SIM | 56. TripleFlash 120.....SIM |
| 9. DoubleFlash 75.....PH.1 | 33. SingleFlash 90.....ALT | 57. SigAlert Cal.....ALT |
| 10. DoubleFlash 75.....PH.2 | 34. SingleFlash 90.....SIM | 58. SigAlert Cal.....SIM |
| 11. DoubleFlash 75.....PH.3 | 35. SingleFlash 120.....ALT | 59. Action 1.....ALT |
| 12. DoubleFlash 75.....PH.4 | 36. SingleFlash 120.....SIM | 60. Action 1.....SIM |
| 13. SingleFlash 75.....PH.1 | 37. SingleFlash 300.....ALT | 61. Action 2.....ALT |
| 14. SingleFlash 75.....PH.2 | 38. SingleFlash 300.....SIM | 62. Action 2.....SIM |
| 15. SingleFlash 75.....PH.3 | 39. DoubleFlash 150.....ALT | 63. CalScan™.....ALT/SIM |
| 16. SingleFlash 75.....PH.4 | 40. DoubleFlash 150.....SIM | 64. ActionScan™.....ALT/SIM |
| 17. ComAlert™ 75.....PH.1 | 41. ComAlert™ 150.....ALT | 65. SteadyFlash 60 |
| 18. ComAlert™ 75.....PH.2 | 42. ComAlert™ 150.....SIM | 66. SteadyFlash 75 |
| 19. ComAlert™ 75.....PH.3 | 43. ActionFlash™ 50.....ALT | 67. SteadyFlash 90 |
| 20. ComAlert™ 75.....PH.4 | 44. ActionFlash™ 50.....SIM | 68. SteadyFlash 120 |
| 21. LongBurst™ 75.....PH.1 | 45. ActionFlash™ 150.....ALT | 69. Steady & Steady |
| 22. LongBurst™ 75.....PH.2 | 46. ActionFlash™ 150.....SIM | |
| 23. LongBurst™ 75.....PH.3 | 47. ModuFlash™.....ALT | |
| 24. LongBurst™ 75.....PH.4 | 48. ModuFlash™.....SIM | |

NOTE: BOLD = California Title XIII Compliant Pattern *Italic* = SYNC Patterns

NOTE: PHASE 1 ALWAYS ALTERNATES WITH PHASE 2
PHASE 3 ALWAYS ALTERNATES WITH PHASE 4

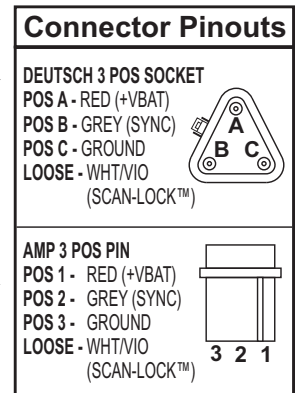
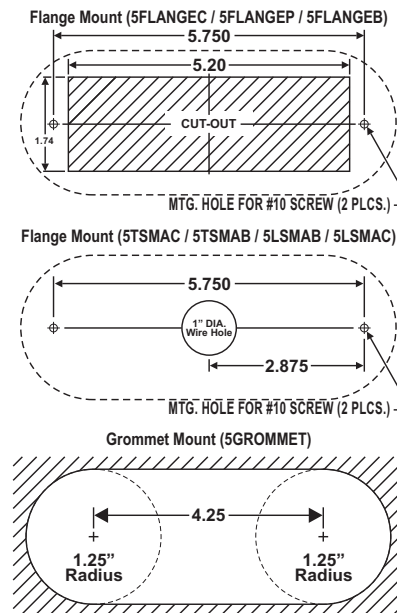

Swivel or Bar Mounts:

These kits include the items shown here, plus (depending on which kit you purchase) the items shown below (except for lightheads & lenses).

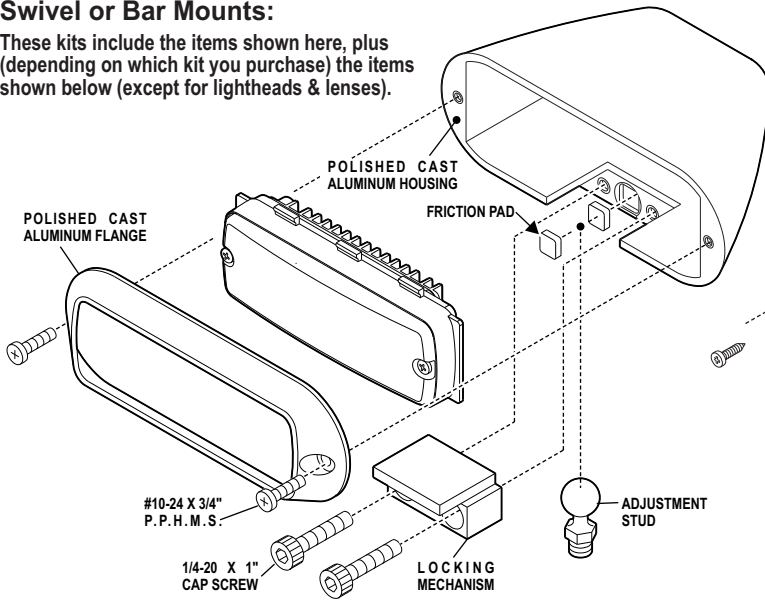

Kit: 5GROMMET

5GROMMET
P/N 01-0463308-00

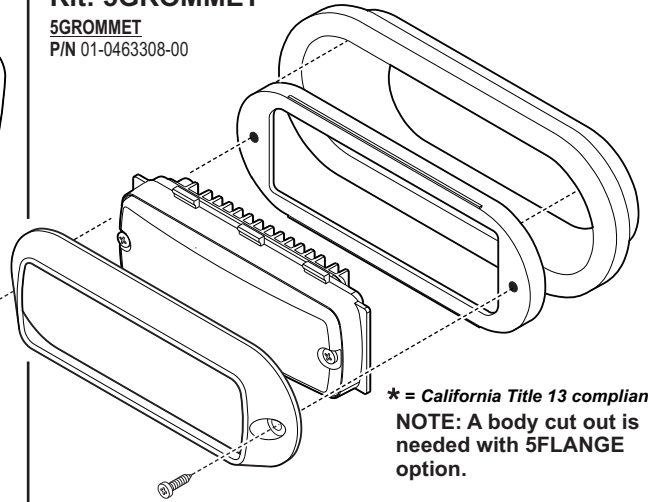

* = California Title 13 compliant
NOTE: A body cut out is needed with 5FLANGE option.

Kit: 5TSMAC & 5TSMAB

5TSMAC Surface Mount Flange Kit
CHROME P/N 01-0463595-01

5TSMAB Surface Mount Flange Kit
BLACK P/N 01-0463595-00

NOTE: No body cut out is needed with 5TSMAC & 5TSMAB flange options.

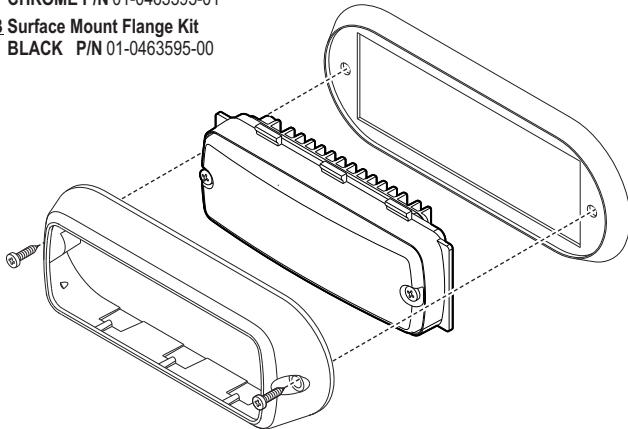

Kit: 5LSMAB & 5LSMAC

5LSMAC Surface Mount Flange Kit
CHROME P/N 01-0464357-01

5LSMAB Surface Mount Flange Kit
BLACK P/N 01-0464357-00

NOTE: No body cut out is needed with 5LSMAC or 5LSMAB flange options.

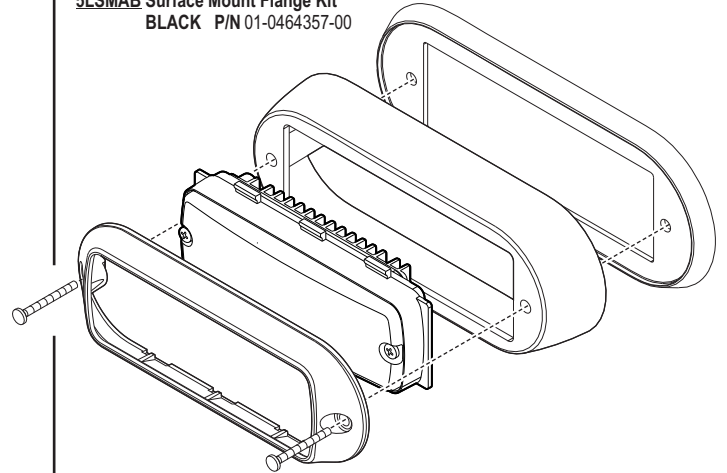

Kit: 5FLANGEB / 5FLANGEC and 5FLANGEP

5FLANGEC / CHROME
P/N 01-0463297-01

5FLANGEP / POLISHED ALUM.
P/N 01-0463297-02

5FLANGEB / BLACK
P/N 01-0463297-00

NOTE: A body cut out is needed with 5FLANGE option.

