

WHELEN[®]

ENGINEERING COMPANY INC.

51 Winthrop Road
Chester, Connecticut 06412-0684
Phone: (860) 526-9504
Internet: www.whelen.com
Sales e-mail: autosale@whelen.com
Customer Service e-mail: custserv@whelen.com

Installation Guide:
Century™ Wrecker Lightbar

Warnings to Installers

Whelen's emergency vehicle warning devices must be properly mounted and wired in order to be effective and safe. Read and follow all of Whelen's written instructions when installing or using this device. Emergency vehicles are often operated under high speed stressful conditions which must be accounted for when installing all emergency warning devices. Controls should be placed within convenient reach of the operator so that they can operate the system without taking their eyes off the roadway. Emergency warning devices can require high electrical voltages and/or currents. Properly protect and use caution around live electrical connections. Grounding or shorting of electrical connections can cause high current arcing, which can cause personal injury and/or vehicle damage, including fire. Many electronic devices used in emergency vehicles can create or be affected by electromagnetic interference. Therefore, after installation of any electronic device it is necessary to test all electronic equipment simultaneously to insure that they operate free of interference from other components within the vehicle. Never power emergency warning equipment from the same circuit or share the same grounding circuit with radio communication equipment. All devices should be mounted in accordance with the manufacturer's instructions and securely fastened to vehicle elements of sufficient strength to withstand the forces applied to the device. Driver and/or passenger air bags (SRS) will affect the way equipment should be mounted. This device should be mounted by permanent installation and within the zones specified by the vehicle manufacturer, if any. Any device mounted in the deployment area of an air bag will damage or reduce the effectiveness of the air bag and may damage or dislodge the device. Installer must be sure that this device, its mounting hardware and electrical supply wiring does not interfere with the air bag or the SRS wiring or sensors. Mounting the unit inside the vehicle by a method other than permanent installation is not recommended as unit may become dislodged during swerving; sudden braking or collision. Failure to follow instructions can result in personal injury. Whelen assumes no liability for any loss resulting from the use of this warning device. **PROPER INSTALLATION COMBINED WITH OPERATOR TRAINING IN THE PROPER USE OF EMERGENCY WARNING DEVICES IS ESSENTIAL TO INSURE THE SAFETY OF EMERGENCY PERSONNEL AND THE PUBLIC.**

Warnings to Users

Whelen's emergency vehicle warning devices are intended to alert other operators and pedestrians to the presence and operation of emergency vehicles and personnel. However, the use of this or any other Whelen emergency warning device does not guarantee that you will have the right-of-way or that other drivers and pedestrians will properly heed an emergency warning signal. Never assume you have the right-of-way. It is your responsibility to proceed safely before entering an intersection, driving against traffic, responding at a high rate of speed, or walking on or around traffic lanes. Emergency vehicle warning devices should be tested on a daily basis to ensure that they operate properly. When in actual use, the operator must ensure that both visual and audible warnings are not blocked by vehicle components (i.e.: open trunks or compartment doors), people, vehicles, or other obstructions. It is the user's responsibility to understand and obey all laws regarding emergency warning devices. The user should be familiar with all applicable laws and regulations prior to the use of any emergency vehicle warning device. Whelen's audible warning devices are designed to project sound in a forward direction away from the vehicle occupants. However, because sustained periodic exposure to loud sounds can cause hearing loss, all audible warning devices should be installed and operated in accordance with the standards established by the National Fire Protection Association.

Safety First

This document provides all the necessary information to allow your Whelen product to be properly and safely installed. Before beginning the installation and/or operation of your new product, the installation technician and operator must read this manual completely. Important information is contained herein that could prevent serious injury or damage.

⚠ WARNING: This product can expose you to chemicals including Methylene Chloride which is known to the State of California to cause cancer, and Bisphenol A, which is known to the State of California to cause birth defects or other reproductive harm. For more information go to www.P65Warnings.ca.gov.

- **Proper installation of this product requires the installer to have a good understanding of automotive electronics, systems and procedures.**
- **Whelen Engineering requires the use of waterproof butt splices and/or connectors if that connector could be exposed to moisture.**
- **Any holes, either created or utilized by this product, should be made both air- and watertight using a sealant recommended by your vehicle manufacturer.**
- **Failure to use specified installation parts and/or hardware will void the product warranty.**
- **If mounting this product requires drilling holes, the installer MUST be sure that no vehicle components or other vital parts could be damaged by the drilling process. Check both sides of the mounting surface before drilling begins. Also de-burr the holes and remove any metal shards or remnants. Install grommets into all wire passage holes.**
- **If this manual states that this product may be mounted with suction cups, magnets, tape or Velcro®, clean the mounting surface with a 50/50 mix of isopropyl alcohol and water and dry thoroughly.**
- **Do not install this product or route any wires in the deployment area of your air bag. Equipment mounted or located in the air bag deployment area will damage or reduce the effectiveness of the air bag, or become a projectile that could cause serious personal injury or death. Refer to your vehicle owner's manual for the air bag deployment area. The User/Installer assumes full responsibility to determine proper mounting location, based on providing ultimate safety to all passengers inside the vehicle.**
- **For this product to operate at optimum efficiency, a good electrical connection to chassis ground must be made. The recommended procedure requires the product ground wire to be connected directly to the NEGATIVE (-) battery post (this does not include products that use cigar power cords).**
- **If this product uses a remote device for activation or control, make sure that this device is located in an area that allows both the vehicle and the device to be operated safely in any driving condition.**
- **Do not attempt to activate or control this device in a hazardous driving situation.**
- **This product contains either strobe light(s), halogen light(s), high-intensity LEDs or a combination of these lights. Do not stare directly into these lights. Momentary blindness and/or eye damage could result.**
- **Use only soap and water to clean the outer lens. Use of other chemicals could result in premature lens cracking (crazing) and discoloration. Lenses in this condition have significantly reduced effectiveness and should be replaced immediately. Inspect and operate this product regularly to confirm its proper operation and mounting condition. Do not use a pressure washer to clean this product.**
- **It is recommended that these instructions be stored in a safe place and referred to when performing maintenance and/or reinstallation of this product.**
- **FAILURE TO FOLLOW THESE SAFETY PRECAUTIONS AND INSTRUCTIONS COULD RESULT IN DAMAGE TO THE PRODUCT OR VEHICLE AND/OR SERIOUS INJURY TO YOU AND YOUR PASSENGERS!**

IMPORTANT! The lightbar should be a minimum of 16" from any radio antennas!

Permanent Mounting / Stud Mount:

Caution: Permanent mounting of this product will require drilling. Be absolutely sure that no other vehicle components could be damaged by this process. Check both sides of the mounting surface before starting. If damage is likely, select a different mounting location.

1. Insert the 2 Stud Mount brackets under the lip in the bottom of the extrusion. (rounded end first) and pivot the bracket so that the other end slides under the other lip in the extrusion.
2. Make sure that the brackets are sitting all the way at each end of the extrusion, then secure them with the supplied allen set screws.
3. Place the lightbar in the exact mounting location. Mark the location of the 2 mounting holes onto the mounting surface, and the area for the wire passage hole. This hole should be located directly below where the wires exit the extrusion.
4. Remove the lightbar and drill the mounting holes as well as the 5/16" dia. wire passage hole. De-burr all the holes and install a rubber grommet (customer supplied) into the wire passage hole.
5. Route the wires through the grommet and to the necessary switches and power source as shown in the wiring diagram.
6. Secure the lightbar to the vehicle using the hardware provided. From the underside of the mounting surface, apply RTV around each mounting hole and the grommeted wire passage hole.

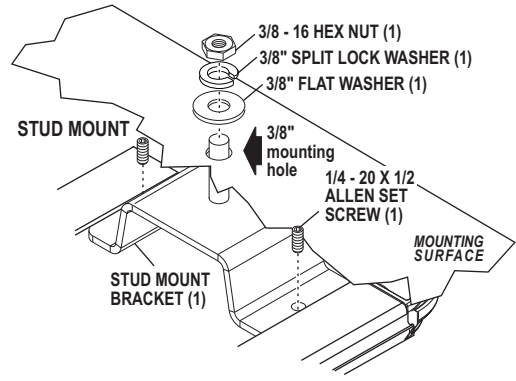
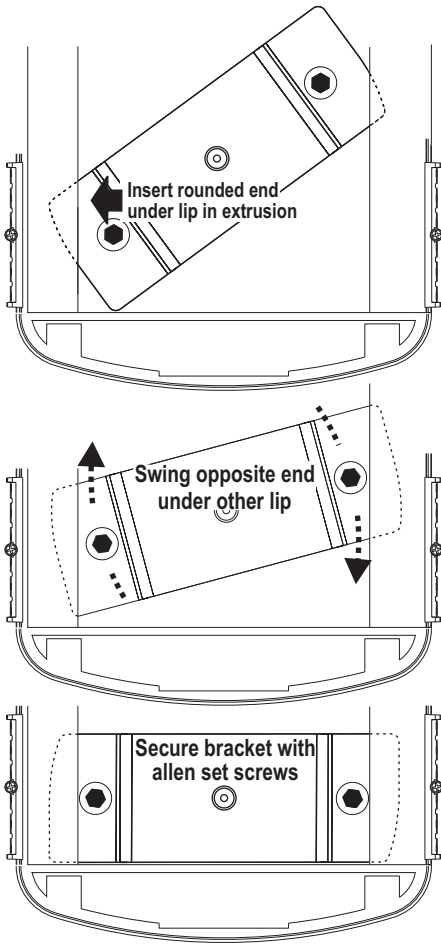

IMPORTANT! It is the responsibility of the installation technician to make sure that the installation and operation of this product will not interfere with or compromise the operation or efficiency of any vehicle equipment! Before returning the vehicle to active service, visually confirm the proper operation of this product, as well as all vehicle components/equipment.

Lightbar Cables:

This lightbar uses a 4-conductor cable for LEDs and a 6 conductor cable for options. There is also a 4 conductor cable for BRAKE-TAIL to connect to your brake lights. Extend the 4 and 6 conductor LED and FUNCTION cables towards your switch panel. The instructions included with your switches will provide switch wiring information. The BRAKE-TAIL cable connects to the brake lights.

WARNING! All Customer supplied wires that connect to the positive terminal of the battery must be sized to supply at least 125% of the maximum operating current and FUSED at the battery to carry that load. DO NOT USE CIRCUIT BREAKERS WITH THIS PRODUCT!

6 Conductor Option Cable:

- WHITE:** Apply +12 volts to activate the Worklight
- GREEN:** Apply +12 volts to activate Pattern Override
- RED:** Apply +12 volts to activate Scan-Lock™
- BLUE:** Apply +12 volts to activate Low Power.

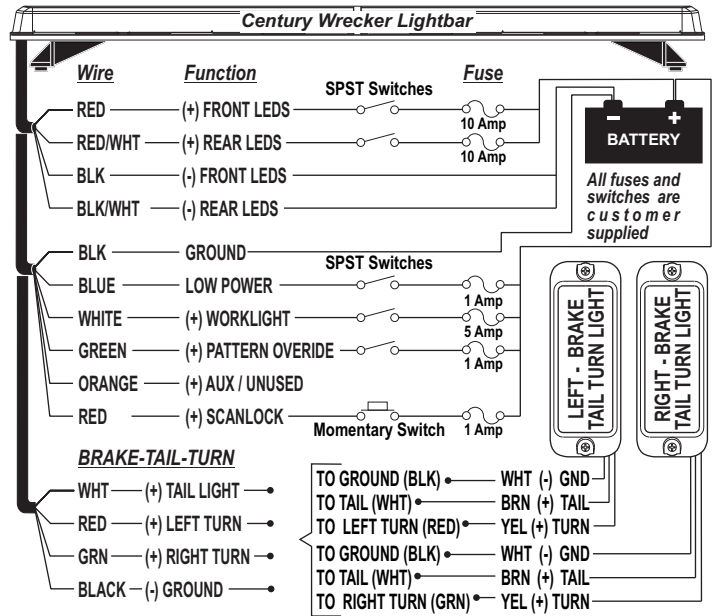

ORG: Available to add option / + 12 volts to activate / Fuse appropriately
BLACK: Ground

RED: Scan-Lock™

LED's must be on for Scan-Lock™ to work.

TO CHANGE PATTERNS: To cycle forward to the next available pattern: Apply +12 volts to the RED wire for less than 1 second and release. To cycle back to the previous pattern: Apply +12 volts to the RED wire for over 1 second and release.

TO CHANGE THE DEFAULT PATTERN: Allow the desired pattern to run for more than 5 seconds. The lighthead will now display this pattern when activated.

TO RESTORE THE FACTORY DEFAULT PATTERN: With power to the lightheads off, apply +12 volts to the RED wire. While still applying +12 volts to the RED wire, turn power to the lightheads back on and the factory default pattern will be displayed.

A normally open momentary switch can be used to control Scan-Lock™.

GREEN: Pattern Override

Applying +12 volts to the GREEN wire while lightheads are activated will change the flash pattern to whatever "pattern override" is programmed for. To program the flash pattern activate the lightbar. Activate *pattern override* by applying +12 volts to the GREEN wire then select a flash pattern using the Scan-Lock™ procedure.

BLUE: Low Power

Applying +12 volts DC to the BLUE wire for more than 1 second holds the lightbar in low power mode until that voltage is removed. A toggle switch is best suited for this.

4 Conductor LED Cable:

- RED:** Apply +12 volts to activate the Front LED's
- RED/WHT:** Apply +12 volts to activate the Rear LED's
- BLACK:** Ground wire for Front LED's
- BLK/WHT:** Ground wire for Rear LED's

4 Conductor Brake-Tail-Turn Cable: Connect as shown above.

- | | | | |
|-------------------------------|---------------------------------|---------------------------------|------------------------------|
| 1. ActionScan™ | 14. SingleFlash 75* Alt. | 27. SingleFlash 90* Alt./Sync. | 40. MicroBurst™ Sim. |
| 2. SignalAlert™ Alt. | 15. SingleFlash 75* Alt./ASync | 28. SingleFlash 90* Sim. | 41. MicroBurst™ Alt./Sim. |
| 3. SignalAlert™ Alt./ASync | 16. SingleFlash 75* Sim. | 29. SingleFlash 90* Alt./Sim. | 42. ActionFlash™ Alt. |
| 4. SignalAlert™ Sim. | 17. SingleFlash 75* Alt. Sim. | 30. SingleFlash 120* Alt. | 43. ActionFlash™ Alt./ASync. |
| 5. SignalAlert™ Alt./Sim. | 18. LongBurst™ Alt. | 31. SingleFlash 120* Alt./Sync. | 44. ActionFlash™ Sim. |
| 6. CometFlash® Alt. | 19. LongBurst™ Alt./ASync. | 32. SingleFlash 120* Sim. | 45. PingPong™ Alt. |
| 7. CometFlash® Alt./ASync | 20. LongBurst™ Sim. | 33. SingleFlash 120* Alt./Sim. | 46. PingPong™ Alt./ASync. |
| 8. CometFlash® Sim. | 21. LongBurst™ Alt./Sim. | 34. SingleFlash 300 Alt. | 47. FlimFlam Alt. |
| 9. CometFlash® Alt./Sim. | 22. SingleFlash 60* Alt. | 35. SingleFlash 300 Alt./Sync. | 48. FlimFlam Alt./ASync. |
| 10. DoubleFlash 75 Alt. | 23. SingleFlash 60* Alt./ASync. | 36. SingleFlash 300 Sim. | 49. ModuFlash™ Alt. |
| 11. DoubleFlash 75 Alt./ASync | 24. SingleFlash 60* Sim. | 37. SingleFlash 300 Alt./Sim. | 50. ModuFlash™ Alt./ASync. |
| 12. DoubleFlash 75 Sim. | 25. SingleFlash 60* Alt./Sim. | 38. MicroBurst™ Alt. | 51. ModuFlash™ Sim. |
| 13. DoubleFlash 75 Alt./Sim. | 26. SingleFlash 90* Alt. | 39. MicroBurst™ Alt./ASync. | 52. ZigZag. |

Alt. = Alternating Sim. = Simultaneous Alt./Sim. = Alternating/Simultaneous Alt./ASync. = Alternating/ASynchronous * = California Title IIIIX Compliant

IMPORTANT WARNING!

CAUTION! DO NOT LOOK DIRECTLY AT THESE LEDS WHILE THEY ARE ON. MOMENTARY BLINDNESS AND/OR EYE DAMAGE COULD RESULT!

IMPORTANT! It is the responsibility of the installation technician to make sure that the installation and operation of this product will not interfere with or compromise the operation or efficiency of any vehicle equipment!

IMPORTANT! Before returning this vehicle to active service, visually confirm the proper operation of this product, as well as all vehicle components/ equipment.

QTY	QTY	QTY	ITEM	PART NUMBER	DESCRIPTION
	*			01-0687191-__	CENTURY WRECKER LTBAR 56"
	*			01-0687191-__	CENTURY WRECKER LTBAR 60"
*				01-0687191-__	CENTURY WRECKER LTBAR 72"
-	-	1	1	11-36D421-053	EXTRUSION, MACHINED, 53.700" CENTURY
-	1	-	2	11-36D421-057	EXTRUSION, MACHINED, 57.100" CENTURY
1	-	-	3	11-36D421-069	EXTRUSION, MACHINED, 69.740" CENTURY
1	1	1	4	21-11245004-1	GROMMET, 1.562" THERMOPLASTIC RUBBER
2	2	2	5	21-7263998-00	PLUG, VENT .750 DIA HOLE LIGHTBAR
1	1	1	6	14-104216-160	SCREW, 10-24 X 1" PPHMS SS
1	1	1	7	46-0743513118	ASSY, CABLE 4/C 14 GA 18" W/CMNL SOCKETS
1	1	1	8	46-0710479-18	ASSY, 6/C 16 GA 18" CABLE STRIP 4"W/61117/STRIP 2
1	1	1	9	02-0241912-00	ASSY, INPUT CABLE BRAKE/TAI LIGHT
1	1	1	10	26-0115663-10	CABLE CLAMP, 5/8"D, 1/2"W .203" MTG HOLE, BLACK
1	1	1	11	13-104111-063	NUT, 10-24 CAD PLATED WHIZ OR STEEL ZINC PLATED
1	1	1	12	26-0215001-06	TY WRAP, 6" BLACK
1	1	1	13	39-0412023-04	HOUSING, 12 POS SCKT F/H COMM MATE-N-LOK
1	1	1	14	01-026D819-00	SUB ASSY, CENTURY WRECKER I/O
20	20	20	15	21-17060704-3	GROMMET, PLASTI-#8/10 .275-.290 SQ HOLE, .057 HD HT
24	24	24	16	15-081416-080	SCREW, 8 X 1/2 PPHMS 410 SS

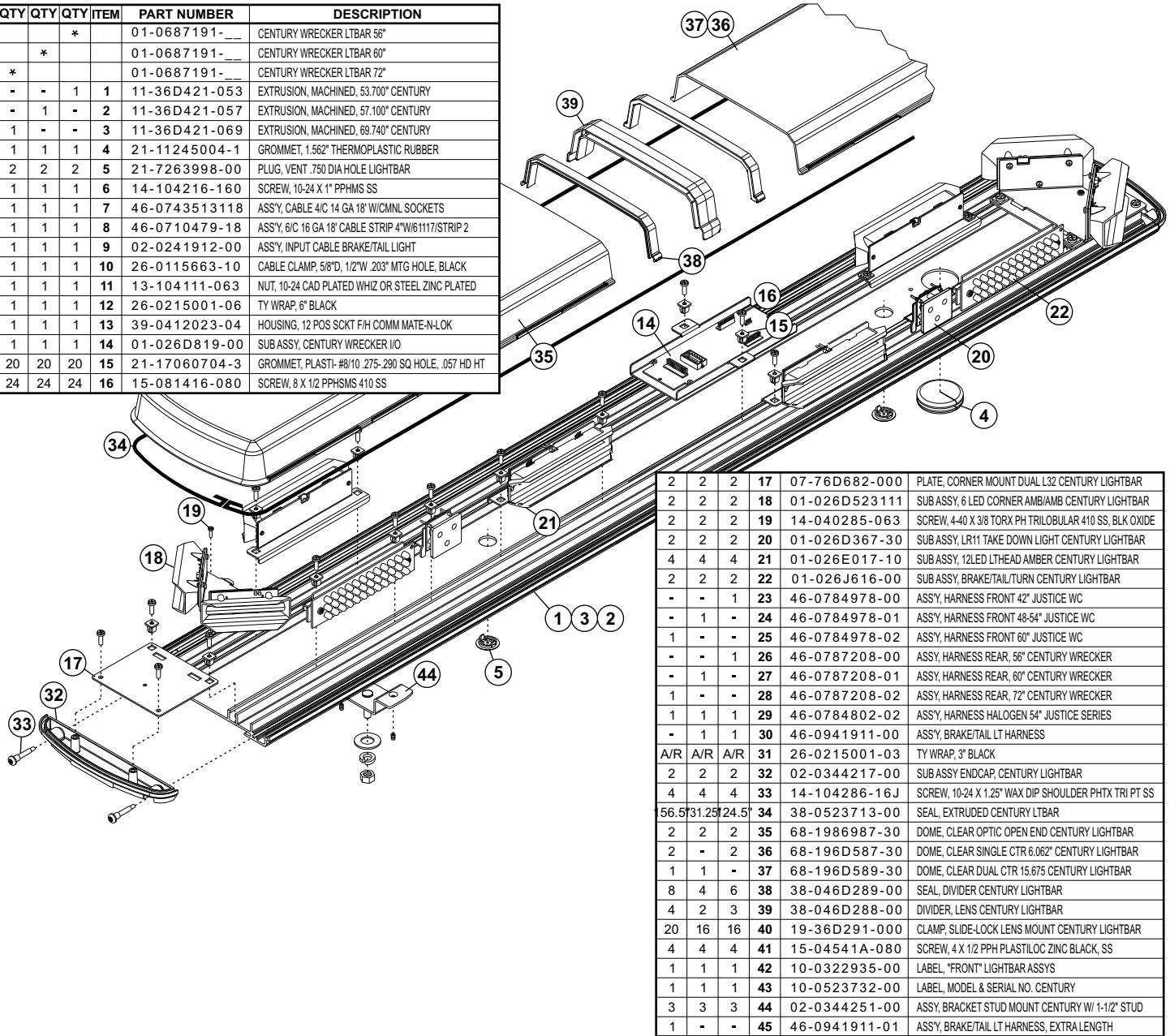

2	2	2	17	07-76D682-000	PLATE, CORNER MOUNT DUAL L32 CENTURY LIGHTBAR
2	2	2	18	01-026D523111	SUB ASSY, 6 LED CORNER AMB/AMB CENTURY LIGHTBAR
2	2	2	19	14-040285-063	SCREW, 4-40 X 3/8 TORX PH TRILOBULAR 410 SS, BLK OXIDE
2	2	2	20	01-026D367-30	SUB ASSY, LR11 TAKE DOWN LIGHT CENTURY LIGHTBAR
4	4	4	21	01-026E017-10	SUB ASSY, 12LED LTHEAD AMBER CENTURY LIGHTBAR
2	2	2	22	01-026J616-00	SUB ASSY, BRAKE/TAI/TURN CENTURY LIGHTBAR
-	-	-	23	46-0784978-00	ASSY, HARNESS FRONT 42" JUSTICE WC
-	1	-	24	46-0784978-01	ASSY, HARNESS FRONT 48-54" JUSTICE WC
1	-	-	25	46-0784978-02	ASSY, HARNESS FRONT 60" JUSTICE WC
-	-	1	26	46-0787208-00	ASSY, HARNESS REAR, 56" CENTURY WRECKER
-	1	-	27	46-0787208-01	ASSY, HARNESS REAR, 60" CENTURY WRECKER
1	-	-	28	46-0787208-02	ASSY, HARNESS REAR, 72" CENTURY WRECKER
1	1	1	29	46-0784802-02	ASSY, HARNESS HALOGEN 54" JUSTICE SERIES
-	1	1	30	46-0941911-00	ASSY, BRAKE/TAI/LT HARNESS
A/R	A/R	A/R	31	26-0215001-03	TY WRAP, 3" BLACK
2	2	2	32	02-0344217-00	SUB ASSY ENDCAP, CENTURY LIGHTBAR
4	4	4	33	14-104286-16J	SCREW, 10-24 X 1.25" WAX DIP SHOULDER PHTX TRI PT SS
56.5	31.25	24.5	34	38-0523713-00	SEAL, EXTRUDED CENTURY LTBAR
2	2	2	35	68-1986987-30	DOME, CLEAR OPTIC OPEN END CENTURY LIGHTBAR
2	-	2	36	68-196D587-30	DOME, CLEAR SINGLE CTR 6.062" CENTURY LIGHTBAR
1	1	-	37	68-196D589-30	DOME, CLEAR DUAL CTR 15.675 CENTURY LIGHTBAR
8	4	6	38	38-046D289-00	SEAL, DIVIDER CENTURY LIGHTBAR
4	2	3	39	38-046D288-00	DIVIDER, LENS CENTURY LIGHTBAR
20	16	16	40	19-36D291-000	CLAMP, SLIDE-LOCK LENS MOUNT CENTURY LIGHTBAR
4	4	4	41	15-04541A-080	SCREW, 4 X 1/2 PPH PLASTILOC ZINC BLACK, SS
1	1	1	42	10-0322935-00	LABEL, "FRONT" LIGHTBAR ASSYS
1	1	1	43	10-0523732-00	LABEL, MODEL & SERIAL NO. CENTURY
3	3	3	44	02-0344251-00	ASSY, BRACKET STUD MOUNT CENTURY W/ 1-1/2" STUD
1	-	-	45	46-0941911-01	ASSY, BRAKE/TAI/LT HARNESS, EXTRA LENGTH