

WHELEN[®]

ENGINEERING COMPANY INC.

51 Winthrop Road
Chester, Connecticut 06412-0684
Phone: (860) 526-9504
Internet: www.whelen.com
Sales e-mail: autosale@whelen.com
Customer Service e-mail: custserv@whelen.com

Installation Guide:
Traffic Advisor™ System
Models: TA4437M, TA437M1, TA437M2

Warnings to Installers

Whelen's emergency vehicle warning devices must be properly mounted and wired in order to be effective and safe. Read and follow all of Whelen's written instructions when installing or using this device. Emergency vehicles are often operated under high speed stressful conditions which must be accounted for when installing all emergency warning devices. Controls should be placed within convenient reach of the operator so that they can operate the system without taking their eyes off the roadway. Emergency warning devices can require high electrical voltages and/or currents. Properly protect and use caution around live electrical connections. Grounding or shorting of electrical connections can cause high current arcing, which can cause personal injury and/or vehicle damage, including fire. Many electronic devices used in emergency vehicles can create or be affected by electromagnetic interference. Therefore, after installation of any electronic device it is necessary to test all electronic equipment simultaneously to insure that they operate free of interference from other components within the vehicle. Never power emergency warning equipment from the same circuit or share the same grounding circuit with radio communication equipment. All devices should be mounted in accordance with the manufacturer's instructions and securely fastened to vehicle elements of sufficient strength to withstand the forces applied to the device. Driver and/or passenger air bags (SRS) will affect the way equipment should be mounted. This device should be mounted by permanent installation and within the zones specified by the vehicle manufacturer, if any. Any device mounted in the deployment area of an air bag will damage or reduce the effectiveness of the air bag and may damage or dislodge the device. Installer must be sure that this device, its mounting hardware and electrical supply wiring does not interfere with the air bag or the SRS wiring or sensors. Mounting the unit inside the vehicle by a method other than permanent installation is not recommended as unit may become dislodged during swerving; sudden braking or collision. Failure to follow instructions can result in personal injury. Whelen assumes no liability for any loss resulting from the use of this warning device. **PROPER INSTALLATION COMBINED WITH OPERATOR TRAINING IN THE PROPER USE OF EMERGENCY WARNING DEVICES IS ESSENTIAL TO INSURE THE SAFETY OF EMERGENCY PERSONNEL AND THE PUBLIC.**

Warnings to Users

Whelen's emergency vehicle warning devices are intended to alert other operators and pedestrians to the presence and operation of emergency vehicles and personnel. However, the use of this or any other Whelen emergency warning device does not guarantee that you will have the right-of-way or that other drivers and pedestrians will properly heed an emergency warning signal. Never assume you have the right-of-way. It is your responsibility to proceed safely before entering an intersection, driving against traffic, responding at a high rate of speed, or walking on or around traffic lanes. Emergency vehicle warning devices should be tested on a daily basis to ensure that they operate properly. When in actual use, the operator must ensure that both visual and audible warnings are not blocked by vehicle components (i.e.: open trunks or compartment doors), people, vehicles, or other obstructions. It is the user's responsibility to understand and obey all laws regarding emergency warning devices. The user should be familiar with all applicable laws and regulations prior to the use of any emergency vehicle warning device. Whelen's audible warning devices are designed to project sound in a forward direction away from the vehicle occupants. However, because sustained periodic exposure to loud sounds can cause hearing loss, all audible warning devices should be installed and operated in accordance with the standards established by the National Fire Protection Association.

Safety First

This document provides all the necessary information to allow your Whelen product to be properly and safely installed. Before beginning the installation and/or operation of your new product, the installation technician and operator must read this manual completely. Important information is contained herein that could prevent serious injury or damage.

⚠ WARNING: This product can expose you to chemicals including Methylene Chloride which is known to the State of California to cause cancer, and Bisphenol A, which is known to the State of California to cause birth defects or other reproductive harm. For more information go to www.P65Warnings.ca.gov.

- **Proper installation of this product requires the installer to have a good understanding of automotive electronics, systems and procedures.**
- **Whelen Engineering requires the use of waterproof butt splices and/or connectors if that connector could be exposed to moisture.**
- **Any holes, either created or utilized by this product, should be made both air- and watertight using a sealant recommended by your vehicle manufacturer.**
- **Failure to use specified installation parts and/or hardware will void the product warranty.**
- **If mounting this product requires drilling holes, the installer MUST be sure that no vehicle components or other vital parts could be damaged by the drilling process. Check both sides of the mounting surface before drilling begins. Also de-burr the holes and remove any metal shards or remnants. Install grommets into all wire passage holes.**
- **If this manual states that this product may be mounted with suction cups, magnets, tape or Velcro®, clean the mounting surface with a 50/50 mix of isopropyl alcohol and water and dry thoroughly.**
- **Do not install this product or route any wires in the deployment area of your air bag. Equipment mounted or located in the air bag deployment area will damage or reduce the effectiveness of the air bag, or become a projectile that could cause serious personal injury or death. Refer to your vehicle owner's manual for the air bag deployment area. The User/Installer assumes full responsibility to determine proper mounting location, based on providing ultimate safety to all passengers inside the vehicle.**
- **For this product to operate at optimum efficiency, a good electrical connection to chassis ground must be made. The recommended procedure requires the product ground wire to be connected directly to the NEGATIVE (-) battery post (this does not include products that use cigar power cords).**
- **If this product uses a remote device for activation or control, make sure that this device is located in an area that allows both the vehicle and the device to be operated safely in any driving condition.**
- **Do not attempt to activate or control this device in a hazardous driving situation.**
- **This product contains either strobe light(s), halogen light(s), high-intensity LEDs or a combination of these lights. Do not stare directly into these lights. Momentary blindness and/or eye damage could result.**
- **Use only soap and water to clean the outer lens. Use of other chemicals could result in premature lens cracking (crazing) and discoloration. Lenses in this condition have significantly reduced effectiveness and should be replaced immediately. Inspect and operate this product regularly to confirm its proper operation and mounting condition. Do not use a pressure washer to clean this product.**
- **It is recommended that these instructions be stored in a safe place and referred to when performing maintenance and/or reinstallation of this product.**
- **FAILURE TO FOLLOW THESE SAFETY PRECAUTIONS AND INSTRUCTIONS COULD RESULT IN DAMAGE TO THE PRODUCT OR VEHICLE AND/OR SERIOUS INJURY TO YOU AND YOUR PASSENGERS!**

Installation: Mounting the Traffic Advisor™

IMPORTANT: The mounting hardware shown here **DOES NOT** come with the light. The mounting kit shown here is purchased separately. If this kit is not used, it is the customer's responsibility to determine the best mounting method/style for their specific application.

1. Remove the two lower brackets of the mounting feet from the mounting kit and secure them to the upper brackets with the supplied hardware (Fig. 1).
2. Slide mounting feet to their desired position inside the groove in the extrusion and secure with supplied hardware.
3. Loosen the hex nuts holding the upper and lower brackets together and place the T/A in the desired position on the proposed mounting surface. Adjust the lower brackets of the mounting feet to rest firmly on the mounting surface and trace the outline of these brackets onto that surface. If the T/A power cable is to pass through the mounting surface, be sure to mark the area for this passage hole.

4. Remove the T/A from the mounting surface and separate the lower brackets of the mounting feet from the upper brackets. Align the lower brackets with the outlines traced in the previous step and trace the mounting hole locations onto the mounting surface. **Make sure that the lower bracket is facing in the same direction as it was when it was outlined on the mounting surface in step 3.**
5. Examine the back side of the mounting surface to insure that no damage will occur when drilling the mounting holes. Drill the mounting holes with a 7/32" drill. If a wire passage hole has been marked, drill the hole using a drill bit sized for the cable and a rubber grommet (customer supplied).
6. Secure the lower brackets to the mounting surface.
7. Lower the T/A assembly onto the two lower brackets and secure both brackets together with the supplied mounting hardware. Before tightening the upper and lower brackets together, adjust the T/A to an angle best suited to its mounting location.
8. Slide the cable through the wire passage hole and route the cable to the control head. Refer to your control head manual for wiring.

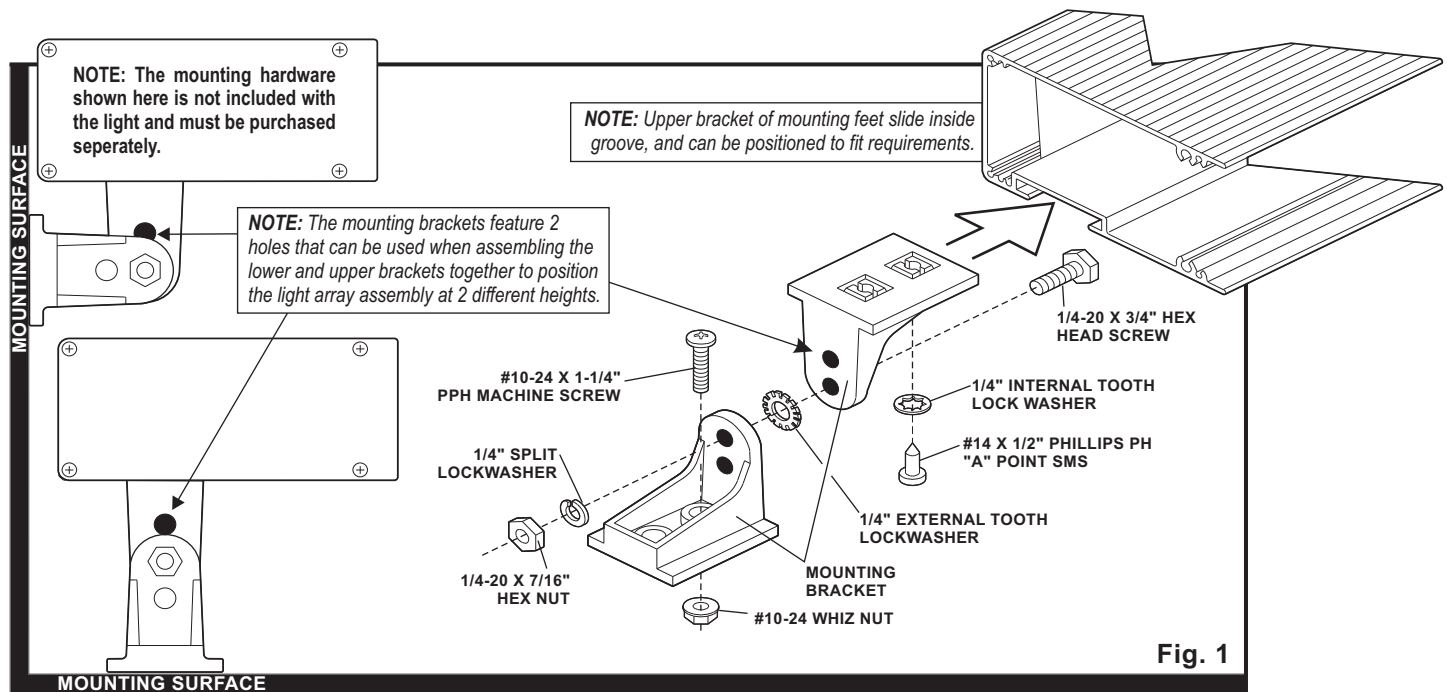

Wiring:

CAUTION: Do not connect the T/A System to power until the installation is completed. When servicing or troubleshooting always disconnect it from the power source.

Refer to the wiring diagram on the last page and wire as shown.

WARNING! All customer supplied wires that connect to the positive terminal of the battery must be sized to supply at least 125% of the maximum operating current and **FUSED** at the battery to carry that load. **DO NOT USE CIRCUIT BREAKERS WITH THIS PRODUCT!**

Servicing the Light Array:

1. Disconnect the lightbar from the power source and remove the end cap on the side that you wish to replace the lighthouse.
2. Slide the lighthouse you wish to replace out of the base (Fig. 2).
3. Cut the wires off of the old lighthouse (removing the old butt splice). Then, using a new butt splice, install the new lighthouse then slide the lighthouse(s) back into the base.

NOTE: Replacing a lens does not require removing the lighthouse.

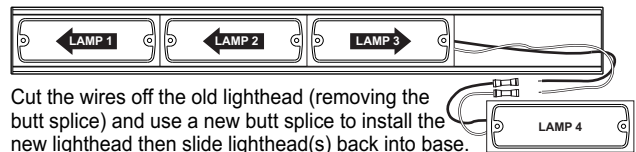

* ITEM	PART NUMBER	DESCRIPTION
1	01-0688474-A	TRAFFIC ADVISOR STRAIGHT 4 TIR 12VDC/AMBER
2	11-4463394-B00	HOUSING, 4 LIGHT
3	01-0266030012	TIR STEADY - AMB/AMB
4	68-1963428-10	LENS, AMBER OPTIC 500
5	15-065419-060	#6 X 3/8 PPH PLASTI
6	21-11121603-0	GROMMET 3/8"
A/R	46-0764544-01	CABLE ASSY 4 LIGHT TRAFFIC ADVISOR 15'
A/R	46-0764544-02	CABLE ASSY 4 LIGHT TRAFFIC ADVISOR 30'
A/R	46-0764544-03	CABLE ASSY 4 LIGHT TRAFFIC ADVISOR 50'
1	26-0121053-00	CABLE CLAMP
10	39-0917517-06	HOUSING, PLUG, 2 X 3 POS UMNL
11	39-1V17144-00	SEAL, INTERFACE 6 POS
12	39-1V17144-01	SEAL, WIRE 6 POS
13	39-1V17144-02	PLUG, KEYING UNIVERSAL MATE-N-LOK
14	46-0764543-00	HARNES, ASSEMBLY 4 LIGHT TRAFFIC ADVISOR
15	39-0406323-04	HOUSING, 6 POS PIN AMP
2	11-241413-001	ENDCAP, BLACK
2	17-38-0125020-02	SPACER, BLACK NEOPRENE SPONGE PSA ONE SIDE 1.000"
8	14-0622216-083	ISCREW, 6-32 X 1/2" PPHMS SELF-TAP

PART NUMBER KEY:
01-0688474-

COLOR & VOLTAGE
A = AMBER 12 VDC

CABLE LENGTH
0 = 15'
1 = 30'
2 = 50'

CABLE LENGTH
COLOR & VOLTAGE

LED OPTIC LENS:
AMBER 68-1963428-10

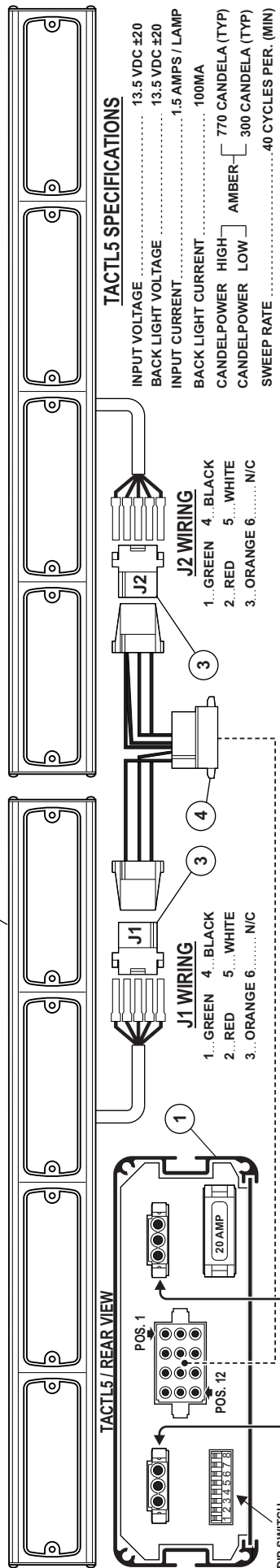
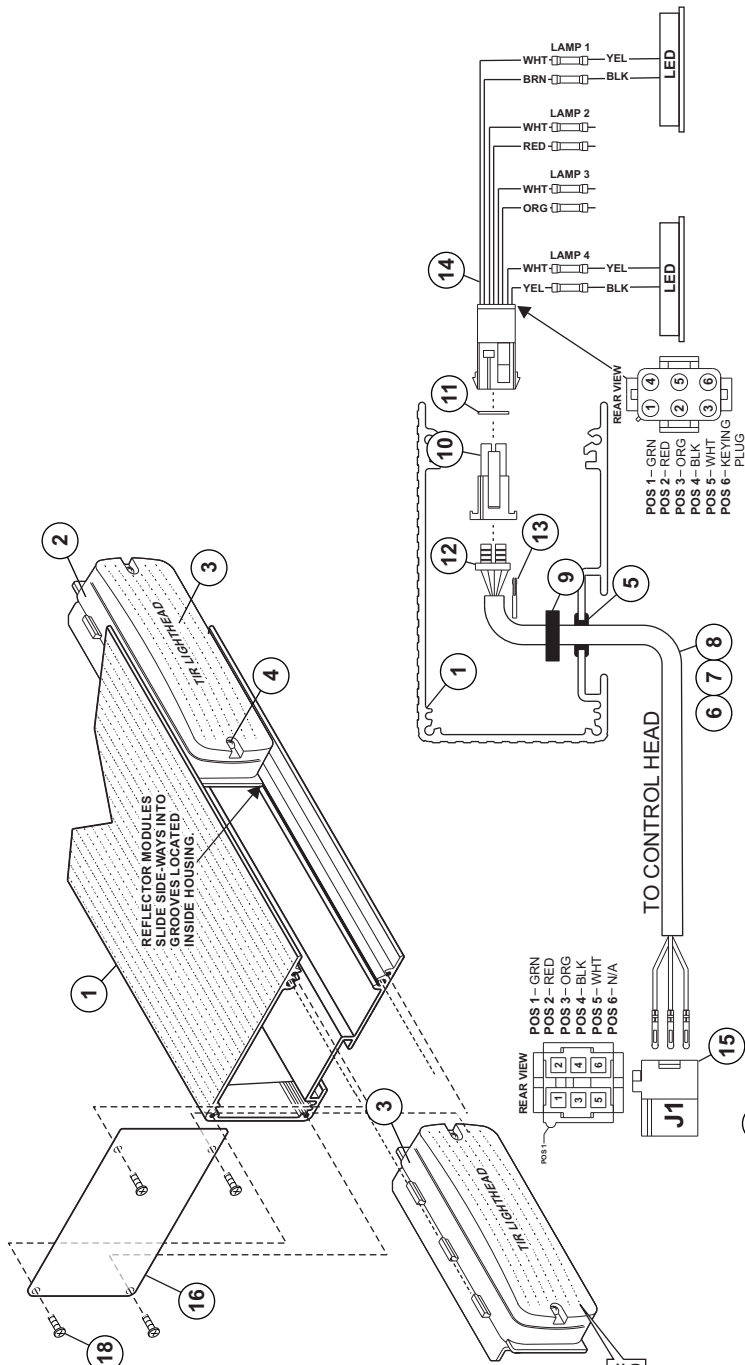

TACTL5 SPECIFICATIONS

INPUT VOLTAGE 13.5 VDC ±20
 BACK LIGHT VOLTAGE 13.5 VDC ±20
 INPUT CURRENT 1.5 AMPS / LAMP
 BACK LIGHT CURRENT 100MA
 CANDELPPOWER HIGH 770 CANDELA (TYP)
 CANDELPPOWER LOW 300 CANDELA (TYP)
 SWEEP RATE40 CYCLES PER. (MIN)

QTY	QTY/ITEM	PART NUMBER	DESCRIPTION
*		01-15888474-A0	SYSTEM ASSEMBLY TA4437M 15'
*		01-15888474-A1	SYSTEM ASSEMBLY TA4437M 30'
*		01-15888474-A2	SYSTEM ASSEMBLY TA4437M2 50'
1	1	01-0688086-00	TACTL5 CONTROL HD
2	2	01-0688474-A	MODEL TA4437M TRAFFIC ADVISOR ASSY
REF	REF	39-0406323-04	6 POS PIN HOUSING
1	1	46-0942423-00	INPUT CONNECTOR ASSEMBLY

