

# WHELEN<sup>®</sup>

## ENGINEERING COMPANY

51 Winthrop Road  
Chester, Connecticut 06412-0684  
Phone: (860) 526-9504  
Internet: [www.whelen.com](http://www.whelen.com)  
Sales e-mail: [autosale@whelen.com](mailto:autosale@whelen.com)  
Customer Service e-mail: [custserv@whelen.com](mailto:custserv@whelen.com)

Installation Guide: Core-C™  
Model: CCP9

### Warnings to Installers

Whelen's emergency vehicle warning devices must be properly mounted and wired in order to be effective and safe. Read and follow all of Whelen's written instructions when installing or using this device. Emergency vehicles are often operated under high speed stressful conditions which must be accounted for when installing all emergency warning devices. Controls should be placed within convenient reach of the operator so that they can operate the system without taking their eyes off the roadway. Emergency warning devices can require high electrical voltages and/or currents. Properly protect and use caution around live electrical connections. Grounding or shorting of electrical connections can cause high current arcing, which can cause personal injury and/or vehicle damage, including fire. Many electronic devices used in emergency vehicles can create or be affected by electromagnetic interference. Therefore, after installation of any electronic device it is necessary to test all electronic equipment simultaneously to insure that they operate free of interference from other components within the vehicle. Never power emergency warning equipment from the same circuit or share the same grounding circuit with radio communication equipment. All devices should be mounted in accordance with the manufacturer's instructions and securely fastened to vehicle elements of sufficient strength to withstand the forces applied to the device. Driver and/or passenger air bags (SRS) will affect the way equipment should be mounted. This device should be mounted by permanent installation and within the zones specified by the vehicle manufacturer, if any. Any device mounted in the deployment area of an air bag will damage or reduce the effectiveness of the air bag and may damage or dislodge the device. Installer must be sure that this device, its mounting hardware and electrical supply wiring does not interfere with the air bag or the SRS wiring or sensors. Mounting the unit inside the vehicle by a method other than permanent installation is not recommended as unit may become dislodged during swerving; sudden braking or collision. Failure to follow instructions can result in personal injury. Whelen assumes no liability for any loss resulting from the use of this warning device. **PROPER INSTALLATION COMBINED WITH OPERATOR TRAINING IN THE PROPER USE OF EMERGENCY WARNING DEVICES IS ESSENTIAL TO INSURE THE SAFETY OF EMERGENCY PERSONNEL AND THE PUBLIC.**

### Warnings to Users

Whelen's emergency vehicle warning devices are intended to alert other operators and pedestrians to the presence and operation of emergency vehicles and personnel. However, the use of this or any other Whelen emergency warning device does not guarantee that you will have the right-of-way or that other drivers and pedestrians will properly heed an emergency warning signal. Never assume you have the right-of-way. It is your responsibility to proceed safely before entering an intersection, driving against traffic, responding at a high rate of speed, or walking on or around traffic lanes. Emergency vehicle warning devices should be tested on a daily basis to ensure that they operate properly. When in actual use, the operator must ensure that both visual and audible warnings are not blocked by vehicle components (i.e.: open trunks or compartment doors), people, vehicles, or other obstructions. It is the user's responsibility to understand and obey all laws regarding emergency warning devices. The user should be familiar with all applicable laws and regulations prior to the use of any emergency vehicle warning device. Whelen's audible warning devices are designed to project sound in a forward direction away from the vehicle occupants. However, because sustained periodic exposure to loud sounds can cause hearing loss, all audible warning devices should be installed and operated in accordance with the standards established by the National Fire Protection Association.

### Safety First

This document provides all the necessary information to allow your Whelen product to be properly and safely installed. Before beginning the installation and/or operation of your new product, the installation technician and operator must read this manual completely. Important information is contained herein that could prevent serious injury or damage.

**⚠ WARNING:** This product can expose you to chemicals including Lead which is known to the State of California to cause cancer and birth defects or other reproductive harm. For more information go to [www.P65Warnings.ca.gov](http://www.P65Warnings.ca.gov).

- **Proper installation of this product requires the installer to have a good understanding of automotive electronics, systems and procedures.**
- **Whelen Engineering requires the use of waterproof butt splices and/or connectors if that connector could be exposed to moisture.**
- **Any holes, either created or utilized by this product, should be made both air- and watertight using a sealant recommended by your vehicle manufacturer.**
- **Failure to use specified installation parts and/or hardware will void the product warranty.**
- **If mounting this product requires drilling holes, the installer MUST be sure that no vehicle components or other vital parts could be damaged by the drilling process. Check both sides of the mounting surface before drilling begins. Also de-burr the holes and remove any metal shards or remnants. Install grommets into all wire passage holes.**
- **If this manual states that this product may be mounted with suction cups, magnets, tape or Velcro®, clean the mounting surface with a 50/50 mix of isopropyl alcohol and water and dry thoroughly.**
- **Do not install this product or route any wires in the deployment area of your air bag. Equipment mounted or located in the air bag deployment area will damage or reduce the effectiveness of the air bag, or become a projectile that could cause serious personal injury or death. Refer to your vehicle owner's manual for the air bag deployment area. The User/Installer assumes full responsibility to determine proper mounting location, based on providing ultimate safety to all passengers inside the vehicle.**
- **For this product to operate at optimum efficiency, a good electrical connection to chassis ground must be made. The recommended procedure requires the product ground wire to be connected directly to the NEGATIVE (-) battery post (this does not include products that use cigar power cords).**
- **If this product uses a remote device for activation or control, make sure that this device is located in an area that allows both the vehicle and the device to be operated safely in any driving condition.**
- **Do not attempt to activate or control this device in a hazardous driving situation.**
- **This product contains either strobe light(s), halogen light(s), high-intensity LEDs or a combination of these lights. Do not stare directly into these lights. Momentary blindness and/or eye damage could result.**
- **Use only soap and water to clean the outer lens. Use of other chemicals could result in premature lens cracking (crazing) and discoloration. Lenses in this condition have significantly reduced effectiveness and should be replaced immediately. Inspect and operate this product regularly to confirm its proper operation and mounting condition. Do not use a pressure washer to clean this product.**
- **It is recommended that these instructions be stored in a safe place and referred to when performing maintenance and/or reinstallation of this product.**
- **FAILURE TO FOLLOW THESE SAFETY PRECAUTIONS AND INSTRUCTIONS COULD RESULT IN DAMAGE TO THE PRODUCT OR VEHICLE AND/OR SERIOUS INJURY TO YOU AND YOUR PASSENGERS!**

## Installation:

**Important:** Read all warnings before installing this product

### Bail Strap Mount:

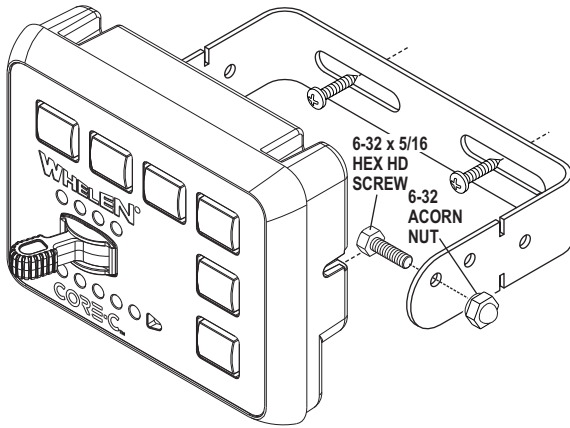

1. Secure the bail strap to the vehicle using customer supplied hardware.
2. Secure bail strap to 6 and Slide control head using the supplied 6-32 x 5/16 HEX HD SCREW and 6-32 ACORN NUT.
3. Extend the wires and connect.

### Keypad ID Label Installation:

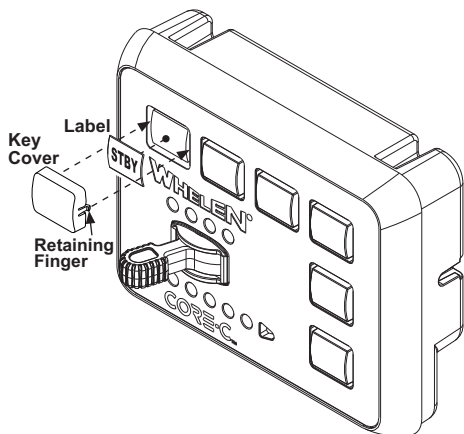

1. Remove the key cover you wish to change. To remove the key cover, gently release the retaining fingers using a small, flat-blade screwdriver or similar tool. Be sure to follow the same removal angle as during installation.
2. Remove the label that best describes the function of the designated button from the label sheet.
3. Position the label onto the key so that it is centered and oriented properly.
4. Press the key cover onto the key until the retaining fingers lock into place. During installation. Do not force the cover onto the key.

**NOTE:** The key cover must be square to the control head

## Wiring:

**Warning!** All customer supplied wires that connect to the positive terminal of the battery must be sized to supply at least 125% of the maximum operating current and **FUSED** at the battery to carry the load. **DO NOT USE CIRCUIT BREAKERS WITH THIS PRODUCT!**

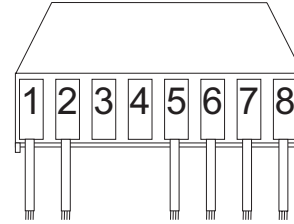

POS.	COLOR	DESCRIPTION
1	GREY	Connects to WeCanX™ Lightbar and/or V2V Sync Mod
2	GREEN	Connects to WeCanX™ Lightbar and/or V2V Sync Mod
3	N/C	-
4	N/C	-
5	RED	Connect to 10-30VDC Fused at 7.5 A
6	BLACK	Connect to Ground
7	RED/WHITE	Connect to an Ignition Controlled 10-30VDC Fused at 1.0 A
8	BLUE	5.0 A Output

**Note:** 22 GA Wire

### Programming:

Attach the unit to the computer using the USB-C cable when programming the system with the Whelen Command™ Software.

**Note:** Charging-only Cables from multiple mobile devices (i.e. cell phones or tablets) are not recommended for data transfer use. Not all are capable of charging and data transfer.

The Core-C™ serves as the main controller of a Whelen WeCanX™ (WCX) Series lightbar. When utilizing Whelen Command® Programming Software, this module can be configured via the USB-C port to provide the necessary instructions that allow the WCX lightbar to function and operate in the desired manner.

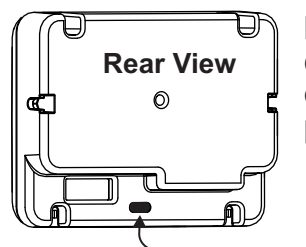

**NOTE:** There is a USB-C connection on the back of the controller for programming.

**Parts List:**

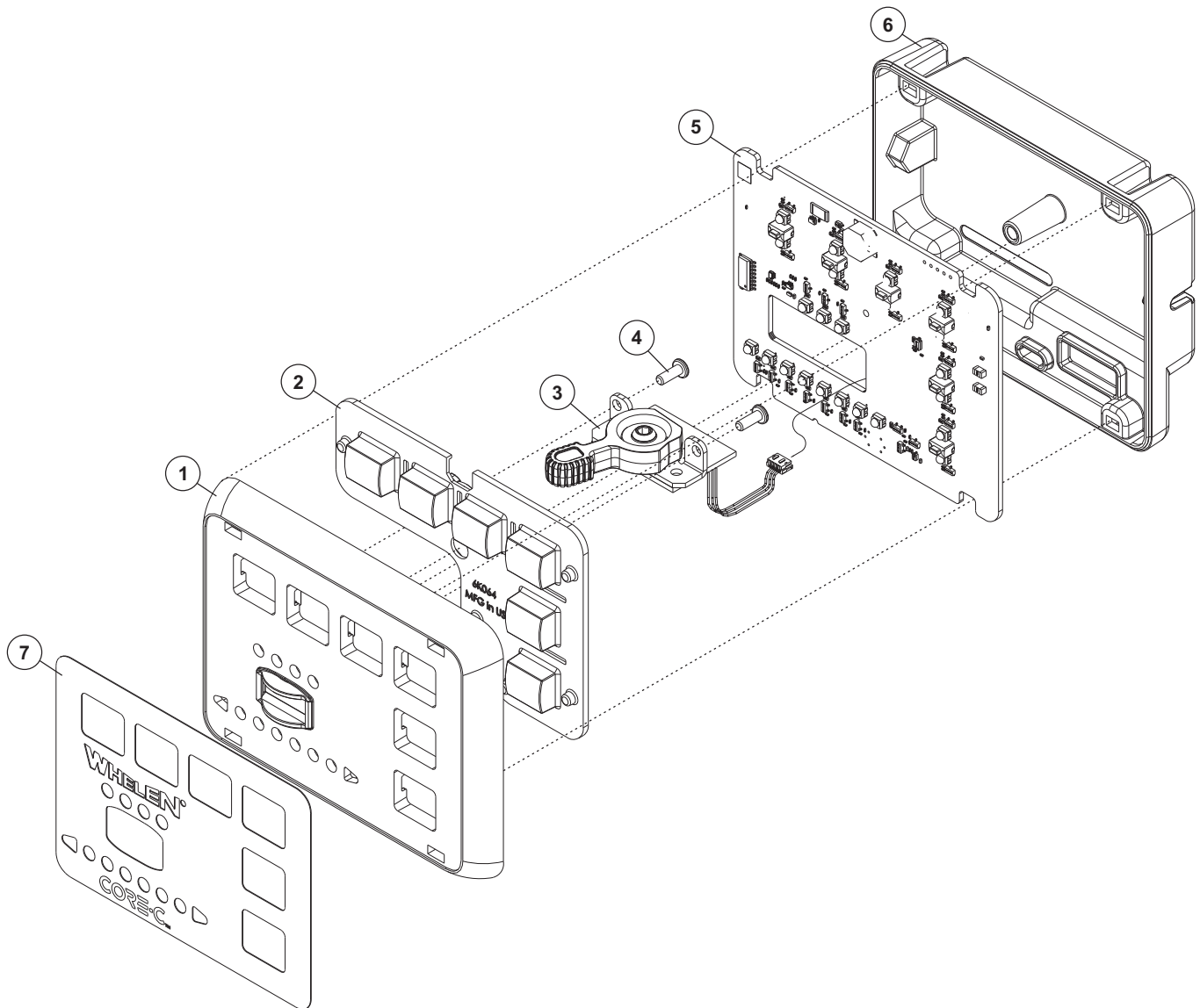

QTY	ITEM	PART NUMBER	DESCRIPTION
*		01-0288812-00	WCC9X CONTROL HEAD
1	1	11-26K062-000	COVER, HOUSING WeCanX™ WCC9
1	2	41-006K064-00	KEYPAD, SILICONE 6 BUTTON, WeCanX™ WCC9 CONTROL HD
1	3	02-036E337-01	ASSY, SLIDE SWITCH RIGHT ANGLE, CT-2MM
2	4	15-045410-060	SCREW, 4 X 3/8" PPH PLASTITE, 48-2 SS 410 BLK OXIDE
1	5	02-016K028-00	ASSY, PCB WCC9X CONTROL HEAD
1	6	11-36K063-000	BASE, HOUSING WeCanX™ WCC9, CONTROL HEAD
1	7	09-046K058-00	OVERLAY, CONTROL HEAD WCC9, WeCanX™
1	8	10-0524032-02	LABEL, P/N, M/N, S/N, WCC9X

# CORE SYSTEM DIAGNOSTIC INDICATORS

## Status Indicator LEDs

All CoreOS devices have both a Status and Activity indicator. In some cases the indicators use a single RGB LED or a separate blue LED and an RGB LED. The indicators are used to communicate system status and error information:

- The **Activity Indicator** is a blue LED that flashes to indicate when the device is processing data and that system communications are active.
- **Status Indicator** is a multi-color RGB LED that indicates to the user system status and error conditions.

The state tables below are used to decode the system status and activity. The first table is for the Bootloader followed by the Application state table.

### State Table - Bootloader

System Status	Status Indicator Colors	Details
Booting	Magenta	The system is booting up. When a CoreOS device firmware update is being installed, this process could take up to 30 seconds.
System Failed to Boot	Red	A fatal error occurred and the system was unable to boot. Contact customer support.

### State Table - Application

System Status	Status Indicator Colors	Details
File Error	Orange	A configuration is missing.
Working	White	A new configuration file has been transferred to the CoreOS device and is actively transferring it to other WeCanX™ devices. Some functionality may be unavailable during this time.
Unconfigured Node	Cyan	The system has a valid configuration file installed, but a device is present on the bus that is not in the configuration.
Active	Green	The system is actively communicating with attached devices and processing events.
Communication (1)	Blue Flash	System communications are active.

1. For a single shared RGB LED a blue flash will override the current color.

## CORE SYSTEM DIAGNOSTIC INDICATOR TROUBLESHOOTING

System Status	Status Indicator Colors	Troubleshooting Steps
Booting	<b>Magenta</b>	A CoreOS device firmware update can take up to 30 seconds to install. If the diagnostic LED is still magenta after 30 seconds, contact customer service.
File Error	<b>Orange</b>	Transfer a valid configuration from Whelen Command™.
Working	<b>White</b>	Refer to “Communications (2)” section for more information about transfer activity.
Unconfigured Node	<b>Cyan</b>	Verify that all peripheral devices connected to Core-S™ are included in your Whelen Command® configuration.
Communication (2)	<b>Blue Flash</b>	The LED will flash blue whenever an input change is detected by Core. For siren configuration, if large DMVs are configured, this can take up to 15 minutes to complete. A full system power cycle is recommended if the communication status does not change. If power or ignition is lost at any point during transfer, the process will start over the next time the unit is powered. The siren will not be functional until this process is complete. If the problem still persists, contact customer support.