

WHELEN[®]

ENGINEERING COMPANY

51 Winthrop Road
Chester, Connecticut 06412-0684
Phone: (860) 526-9504
Internet: www.whelen.com
Sales e-mail: autosale@whelen.com
Customer Service e-mail: custserv@whelen.com

Installation Guide:
Core-R Control System
Model C399R

DANGER! Sirens produce extremely loud emergency warning tones! Exposure to these tones without proper and adequate hearing protection, could cause ear damage and/or hearing loss! The Occupational Safety & Health Administration (www.osha.gov) provides information necessary to determine safe exposure times in Occupational Noise Exposure Section 1910.95. Until you have determined the safe exposure times for your specific application, operators and anyone else in the immediate vicinity should be required to wear an approved hearing protection device. Failure to follow this recommendation could cause hearing loss!

Warnings to Installers

Whelen's emergency vehicle warning devices must be properly mounted and wired in order to be effective and safe. Read and follow all of Whelen's written instructions when installing or using this device. Emergency vehicles are often operated under high speed stressful conditions which must be accounted for when installing all emergency warning devices. Controls should be placed within convenient reach of the operator so that they can operate the system without taking their eyes off the roadway. Emergency warning devices can require high electrical voltages and/or currents. Properly protect and use caution around live electrical connections. Grounding or shorting of electrical connections can cause high current arcing, which can cause personal injury and/or vehicle damage, including fire. Many electronic devices used in emergency vehicles can create or be affected by electromagnetic interference. Therefore, after installation of any electronic device it is necessary to test all electronic equipment simultaneously to insure that they operate free of interference from other components within the vehicle. Never power emergency warning equipment from the same circuit or share the same grounding circuit with radio communication equipment. All devices should be mounted in accordance with the manufacturer's instructions and securely fastened to vehicle elements of sufficient strength to withstand the forces applied to the device. Driver and/or passenger air bags (SRS) will affect the way equipment should be mounted. This device should be mounted by permanent installation and within the zones specified by the vehicle manufacturer, if any. Any device mounted in the deployment area of an air bag will damage or reduce the effectiveness of the air bag and may damage or dislodge the device. Installer must be sure that this device, its mounting hardware and electrical supply wiring does not interfere with the air bag or the SRS wiring or sensors. Mounting the unit inside the vehicle by a method other than permanent installation is not recommended as unit may become dislodged during swerving; sudden braking or collision. Failure to follow instructions can result in personal injury. Whelen assumes no liability for any loss resulting from the use of this warning device. PROPER INSTALLATION COMBINED WITH OPERATOR TRAINING IN THE PROPER USE OF EMERGENCY WARNING DEVICES IS ESSENTIAL TO INSURE THE SAFETY OF EMERGENCY PERSONNEL AND THE PUBLIC.

Warnings to Users

Whelen's emergency vehicle warning devices are intended to alert other operators and pedestrians to the presence and operation of emergency vehicles and personnel. However, the use of this or any other Whelen emergency warning device does not guarantee that you will have the right-of-way or that other drivers and pedestrians will properly heed an emergency warning signal. Never assume you have the right-of-way. It is your responsibility to proceed safely before entering an intersection, driving against traffic, responding at a high rate of speed, or walking on or around traffic lanes. Emergency vehicle warning devices should be tested on a daily basis to ensure that they operate properly. When in actual use, the operator must ensure that both visual and audible warnings are not blocked by vehicle components (i.e.: open trunks or compartment doors), people, vehicles, or other obstructions. It is the user's responsibility to understand and obey all laws regarding emergency warning devices. The user should be familiar with all applicable laws and regulations prior to the use of any emergency vehicle warning device. Whelen's audible warning devices are designed to project sound in a forward direction away from the vehicle occupants. However, because sustained periodic exposure to loud sounds can cause hearing loss, all audible warning devices should be installed and operated in accordance with the standards established by the National Fire Protection Association.

Safety First

This document provides all the necessary information to allow your Whelen product to be properly and safely installed. Before beginning the installation and/or operation of your new product, the installation technician and operator must read this manual completely. Important information is contained herein that could prevent serious injury or damage.

⚠ WARNING: This product can expose you to chemicals including Lead which is known to the State of California to cause cancer and birth defects or other reproductive harm. For more information go to www.P65Warnings.ca.gov.

- Proper installation of this product requires the installer to have a good understanding of automotive electronics, systems and procedures.
- Whelen Engineering requires the use of waterproof butt splices and/or connectors if that connector could be exposed to moisture.
- Any holes, either created or utilized by this product, should be made both air- and watertight using a sealant recommended by your vehicle manufacturer.
- Failure to use specified installation parts and/or hardware will void the product warranty.
- If mounting this product requires drilling holes, the installer MUST be sure that no vehicle components or other vital parts could be damaged by the drilling process. Check both sides of the mounting surface before drilling begins. Also de-burr the holes and remove any metal shards or remnants. Install grommets into all wire passage holes.
- If this manual states that this product may be mounted with suction cups, magnets, tape or Velcro®, clean the mounting surface with a 50/50 mix of isopropyl alcohol and water and dry thoroughly.
- Do not install this product or route any wires in the deployment area of your air bag. Equipment mounted or located in the air bag deployment area will damage or reduce the effectiveness of the air bag, or become a projectile that could cause serious personal injury or death. Refer to your vehicle owner's manual for the air bag deployment area. The User/Installer assumes full responsibility to determine proper mounting location, based on providing ultimate safety to all passengers inside the vehicle.
- For this product to operate at optimum efficiency, a good electrical connection to chassis ground must be made. The recommended procedure requires the product ground wire to be connected directly to the NEGATIVE (-) battery post (this does not include products that use cigar power cords).
- If this product uses a remote device for activation or control, make sure that this device is located in an area that allows both the vehicle and the device to be operated safely in any driving condition.
- It is recommended that these instructions be stored in a safe place and referred to when performing maintenance and/or reinstallation of this product.
- FAILURE TO FOLLOW THESE SAFETY PRECAUTIONS AND INSTRUCTIONS COULD RESULT IN DAMAGE TO THE PRODUCT OR VEHICLE AND/OR SERIOUS INJURY TO YOU AND YOUR PASSENGERS!

**ACTIVATION OF THIS
SIREN MAY DAMAGE
UNPROTECTED EARS!**



CAUTION

Loud siren noise can cause hearing damage and/or loss. Refer to OSHA Section 1910.95 prior to putting ANY siren into service!

Specifications:

Input Voltage	10 - 30 VDC Negative Ground Only
Main Input Current	2 Amps
Stand-by Current (no ignition)	650 μ A
Operating Temperature	-40°C to +65°C
Storage Temperature	-40°C to +70°C
Humidity	99% (Non-condensing)

3 Digital Inputs / 4 Analog Inputs / 1 Ignition Sense

Dimensions

Height	.546 inches
Width	.576 inches
Depth	1.11 inches

Installation:

1. Locate a suitable mounting location. A dry, cool compartment is a good choice.
2. Position the Core-R module on the proposed mounting location. Using an awl or similar tool, scribe the mounting surface where the mounting holes are to be drilled. Make sure that this mounting area allows sufficient ventilation for the Amplifier module's air vents.

Caution: Mounting will require drilling, it is absolutely necessary to make sure that no other vehicle components could be damaged in the process. Check both sides of the mounting surface before starting. If damage is likely, select a different mounting location.

3. Remove the module from its mounting area, and using a drill bit sized for a #8 sheet metal screw, drill a hole in each of the areas scribed in the previous step.

4. Return the module to its mounting location and using #8 x 3/4" sheet metal screws (provided), secure the module onto its mounting surface. Be sure to install a #8 internal tooth lock washer (included) onto each mounting screw before mounting the unit.

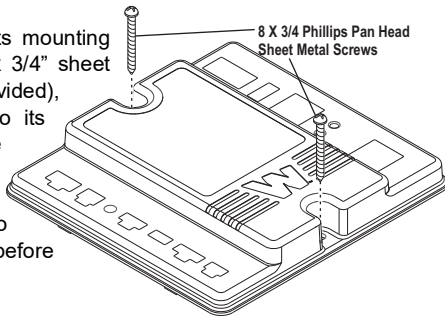

Wiring:

WARNING! All customer supplied wires that connect to the positive terminal of the battery must be sized to supply at least 125% of the maximum operating current and **FUSED** at the battery to carry that load. **DO NOT USE CIRCUIT BREAKERS WITH THIS PRODUCT!**

Wires connecting to the Amp/Relay Module have the proper terminals pre-installed. If the customer needs to re-terminate these wires for any reason, the proper tool **MUST** be used to ensure proper crimping. Use the AMP Pro Crimper II (P/N# 354940-1) with die #90572-2 for items 6-26 and die #58495-2 for items 30-50. **WHELEN DOES NOT RECOMMEND RETERMINATING ANY OF THE ANDERSON™ CONNECTORS.**

Amp/Relay Module Fuses

For ease of access, all of the amp/relay module fuses are accessible from outside the case.

Main Power (J3):

1. Route the RED wire to the positive battery terminal and fuse at **10 AMPS**
2. Route the BLACK wire to the vehicle's chassis ground typically adjacent to the battery.

Programmable Inputs:

There are 3 digital and 4 Analog programmable inputs in the Core-R system.

Digital Inputs (J3) (Pins 2, 3, 4)

These digital inputs can be configured to detect either a positive or ground signal.

Analog Inputs and Ignition Sense (J3)

Analog Inputs (Pins 5, 8, 9, 10)

These inputs can detect a varying, analog voltage range. The output signal line from devices such as a K-9 temperature sensor may be connected to these inputs.

Ignition Sense (Pin 7)

This input should be wired to an ignition signal and controls when the Core-R system turns on (when ignition is detected) and when the system turns off (when ignition line turns off). The Core-R system turning off can be further configured by programming a Shutdown Delay to keep the system active after the ignition signal turns off.

Dry Contact Relay (J4) (See "Hands Free Siren")

- 15 Amp Max, Fused
- Pin 1 is the Normally Open terminal.
- Pin 2 is the relay's Common terminal.
- Pin 3 is the Normally Closed terminal.

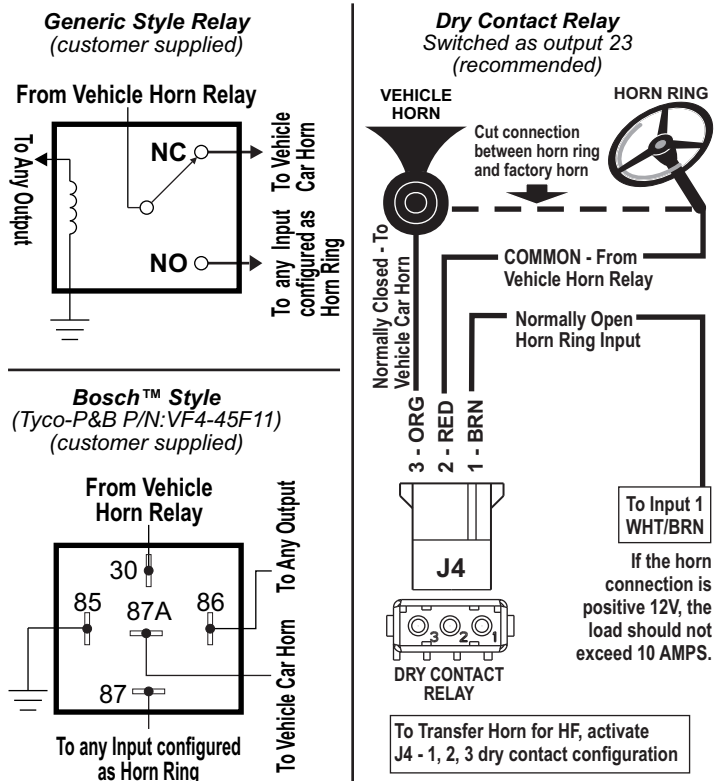

Audio signals (J10):

Radio Rebroadcast (Pins 1, 5)

Two blue wires are used to connect the audio output of your two-way radio to the Whelen Siren Module for radio rebroadcast. This is an optional connection.

NOTE: Radio rebroadcast will NOT work with radios requiring amplified remote speakers! If your remote speaker is amplified (i.e. contains a power amp circuit in the speaker assembly), the signal from the radio will not be appropriate for this input.

Locate the two wires that connect the external speaker to the two-way radio. Splice one of the blue wires into one of the radio's speaker wires, then splice the other blue wire into the other radio speaker wire.

Radio Repeat Volume Adjustment

Locate the Radio Repeat adjustment potentiometer on the left side of the Core-R module. Set the volume of the vehicle's two-way radio to its normal operating level. Press the RAD button on the control head to activate Radio Repeat. As incoming transmissions are received, adjust the Radio Repeat potentiometer to set the desired level. Turn the potentiometer clockwise to increase the level and counter-clockwise to decrease the level.

Auxiliary Audio Output (Pins 4,6)

The white-violet and violet wires are used to connect the audio output of this unit to the auxiliary audio input of a compatible Whelen device.

Microphone (J11):

Attach the microphone extension cable to this connector, route the cable to the desired location in the vehicle and secure the other end to a fixed location and then attach the microphone.

PA Volume Adjustment

To adjust the PA volume refer to the Whelen Command® software for instructions.

Control Head Connection (J6):

Attach the supplied extension cable to J6 and route it to the location desired for the control head, attach the other end to the control head coupler and attach the control head to the coupler.

USB-C Programming Port (J8):

Attach to computer when programming the system with the Whelen Command® Software. **NOTE: Charging-only Cables from multiple mobile devices (i.e. cell phones or tablets) are not recommended for data transfer use. Not all cables are capable of charging and data transfer.**

Ethernet Port (J2):

To be used with optional Whelen Vehicle Safety Gateway (VSG)

CAN Communications (J7): (Connects to vehicle CANports™)

Hands-Free Siren / Optional

You may either use a customer supplied relay capable of handling the current of your vehicle horn connected as shown or the Dry Contact Relay located on the main control box (recommended).

WeCanX® (J5):

Use for connection to WeCanX® peripherals.

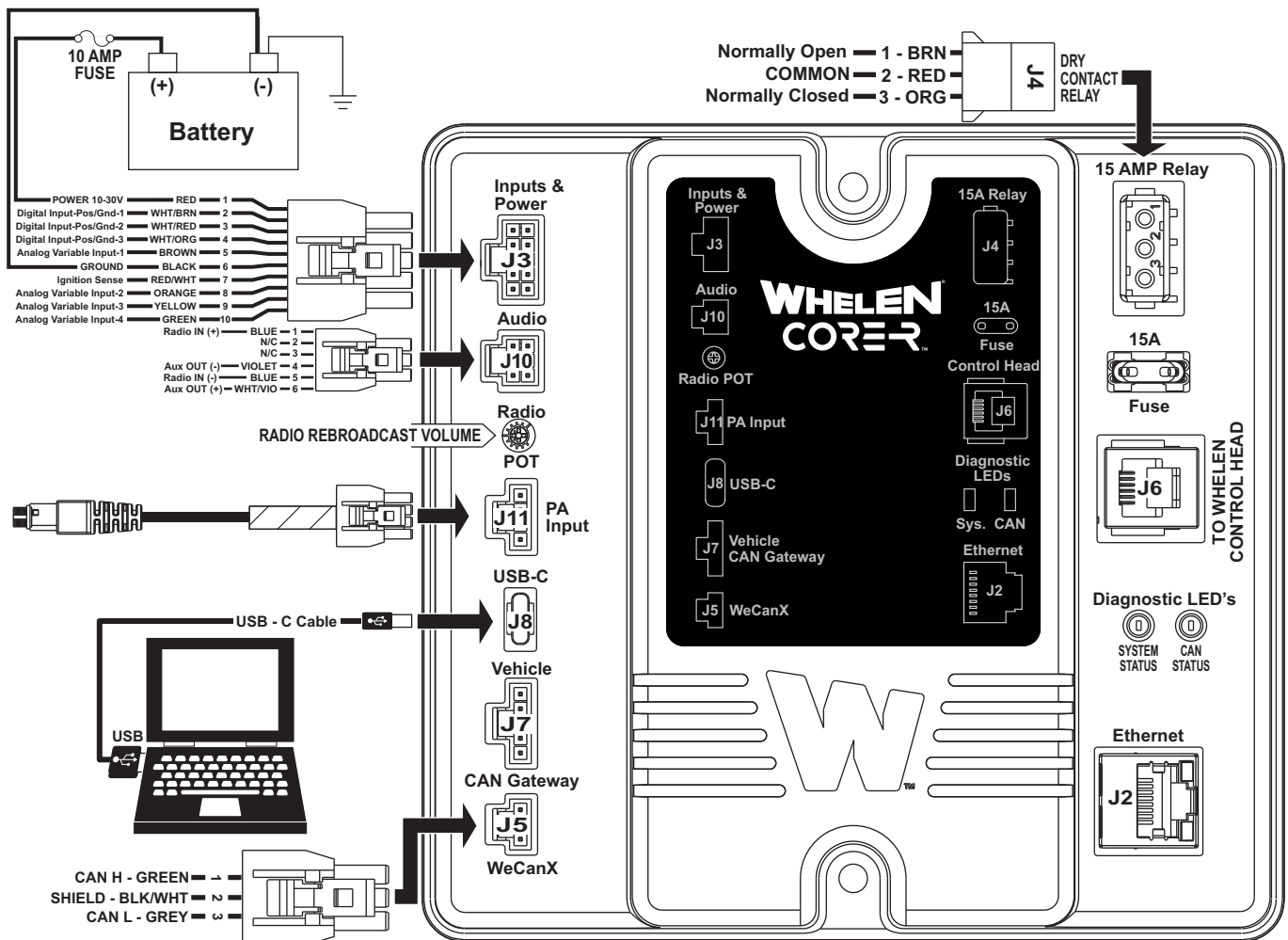

Status Indicator LEDs

- The **Activity Indicator** is a blue LED that flashes to indicate when the device is processing data and that system communications are active.
- **Status Indicator** is a multi-color RGB LED that indicates to the user system status and error conditions.

The state tables below are used to decode the system status and activity. The first table is for the Bootloader followed by the Application state table.

1. For a single shared RGB LED a blue flash will override the current color.

State Table - Bootloader

System Status	Status Indicator Colors	Details
Booting	Magenta	The system is booting up. When a firmware update is being installed, this process could take up to 30 seconds.
No Flash Memory Detected	Magenta	The system was unable to access flash memory.
System Failed to Boot	Red	A fatal error occurred and the system was unable to boot. Contact customer support.

State Table - Application

System Status	Status Indicator Colors	Details
System Memory Error	Red	The application was unable to access flash memory.
File Error	Orange	A configuration is missing.
Working	White	A new configuration file has been transferred to the device and is actively transferring it to other WeCanX devices. Some functionality may be unavailable during this time.
Missing Node	Cyan	The system has a valid configuration file installed, but a device is present in the configuration file that is not connected to the bus.
Active	Green	The system is actively communicating with attached devices and processing events.
Communication (1)	Blue Flash	System communications are active.

Connecting the USB:

In order to fully configure your system, you need to connect USB and open Whelen Command® software. If you plan to check for firmware updates, detect devices to build a new configuration, assign installation ID's or want all devices to accept the full configuration immediately after transfer, then you need to follow the bootup and initialization process first. All devices need to be powered and connected to Core-R via WeCanX® connector before power and ignition are applied to main Core-R. Once the boot-up and initialization process are completed, USB can be connected from a computer with Whelen Command® software. **Note: Power must be applied to Core-R in order to update the firmware of WeCanX® devices.**

If you are just transferring a new configuration, extracting a configuration, or updating the firmware of the main Core-R controller only, all you need to do is connect USB to Core-R via USB-C connector without external power. This provides communication and power to the main controller only. If there is no configuration currently on Core-R, the Status indicator will rapidly blink **Orange** signifying no main power/ignition as well as no configuration. If there is a valid configuration, the Status indicator will rapidly blink **Green** to signify no main power/ignition as well as a valid configuration. If there is no OBDII or analog connections the Activity indicator will be steady **Blue**. **Note: If you send a configuration to Core-R with only USB connected, the configuration will not be sent to all devices until power and ignition are applied to Core-R with WeCanX® connection maintained to powered devices.**

Booting up Core-R:

When you first apply power and ignition to Core-R, the Status indicator will blink **Magenta** to indicate that it is booting up the application code. After about 2 seconds, Core-R should access its application code and go through the initialization process outlined in the next section.

Initializing Devices and Updating Firmware: Initialization:

To ensure proper initialization, make sure all devices are connected via WeCanX® and are powered with 10-30VDC **BEFORE** applying ignition to Core-R. When ignition is applied, Core-R will then register all devices it can communicate with through the WeCanX® bus. The Status indicator will flash **MAGENTA**, and the Activity indicator will flash **Blue** showing message communication.

NOTE: If you have no configuration on Core-R, the Status indicator will also flash Red. If a configuration is present, the Status indicator will also be a steady Green. When the status indicator is no longer flashing **white**, the initialization process is complete. USB can now be plugged into Core-R and hooked up to Whelen Command®.

Updating Firmware:

To update firmware in Whelen Command®, make sure you have gone through the Core-R initialization process and that all devices are still connected via WeCanX® and powered in accordance with their installation instructions. Plug in USB and open Whelen Command® and select Core-R from the product menu. Click the **“W”** icon in the top left corner, and then select “Update Firmware” from the list. Click the refresh button to see a list of all available devices that are connected to Core-R. Verify that every device you have connected is displaying its firmware version; if there are any missing devices, restart the initialization process and try again. Update the firmware of any device that needs it and do not remove WeCanX® connection or power until this process has been completed. Whelen Command® will inform you when the process is completed. When a firmware update is initialized for a device, the diagnostic indicator will slowly flash **Blue** to indicate that it is in the boot-loader and that it recognizes its application code. The firmware update is done one device at a time and when the actual transfer of data is taking place, the diagnostic indicator on the specific device being updated will start blinking **Blue** faster to indicate that its current application data is

being modified. While firmware is updating, the Activity indicator on Core-R will be blinking **Blue** to show activity. **Note: When the peripheral devices have finished updating, the diagnostic indicator on each respective device will turn off unless the diagnostic indicators are configured to be on, in which case they will turn Green when finished.**

Troubleshooting Firmware Updates:

If Whelen Command® informs you that the transfer failed, unplug USB and cycle power to all units and reinitialize the system. Then plug USB back into Core-R and hit the refresh button on the Whelen Command® “Update Firmware” page. Verify that all devices are up to date and repeat the firmware update process if firmware is not up to date. If a device fails to update and all connections are intact, its diagnostic indicator will remain blinking blue to indicate that it is in the boot loader. After re-initializing the system, the device will show up in the “Update Firmware” page with firmware version “Unknown”. From there you can then update the firmware to the newest version. **Note: If at any point your device stops working and you have verified that all the proper connections are intact, re-initialize and check for firmware updates.**

Configuring Devices:

The fastest and easiest way to configure your system is immediately after the initialization and firmware update processes are complete. Having your entire system up to date and still communicating with Core-R allows you to import connected devices into a brand-new configuration using the “Detect via USB” in the “My Hardware” page. All devices presently communicating with Core-R will populate the hardware list. There are certain types of devices that are not automatically populated due to the need of further configuration such as lightbars, Inner Edges and Traffic Advisors. Whelen Command® will prompt the user of the devices that these types of devices are connected but are not automatically populated on the list. **Note: Any device that you have multiples of need to have their installation ID configured.**

Installation IDs

Whelen Command® will prompt you that the installation IDs are not set if you “detect via USB” multiples of the same device type but, as a rule, if you have more than one of the same device type, you need to set the installation ID manually. For Example, two Remote 16s would need their IDs set but one Remote 16 and one Remote 8 would not, or two Arges Remote Spotlights would need their IDs set but one Arges Remote Spotlight and one Arges Profocus would not. Click on the **“W”** icon in the top left of the “My Hardware” page and select “Assign Installation IDs”. The easiest way to set them is one at a time so that you know which one you are setting. All devices you are setting will have a default ID of unassigned. Unplug all the devices you plan to set except for one. Refresh the list and select the number you want from the drop-down menu, check the box next to the device and then click assign. After you have assigned the device you can add each subsequent device one at a time and iterate the installation ID. If you have already set installation IDs before you “Detect via USB”, Whelen Command® will automatically populate the hardware list with the correct configuration ID to match the Installation ID.

Note: The installation ID numbers only differentiate between devices of the same device type, meaning that you can have multiple devices with the same installation ID if they are different device types.

Troubleshooting Installation IDs:

Anytime you have more than one of the same device types in your configuration and only one of them is working, the installation ID may not have been set. After you have checked to make sure you have proper connections, and the initialization and firmware process has been completed, check to make sure all identical device types have installation IDs set.

Setting Device Diagnostic Indicators:

The diagnostic indicators on the main Core-R controller are always on so that the user has more resolution as to what state the system is in.

Individual devices connected to Core-R need to be configured manually in the configuration itself. It is recommended that you always enable the diagnostic indicators on all WeCanX® devices in your configuration. This will enable you to visually see the status of the devices, and to determine what state the device is in as well as if the device has gone to sleep. To turn on diagnostic indicators, go into configuration settings and select diagnostic indicators. From there you can choose which devices you would like to enable and the intensities of the indicators. **NOTE: The diagnostic indicators are very useful for following the progress of large configuration transfers to external sirens.**

CORE-R SYSTEM DIAGNOSTIC INDICATORS



Transferring Configuration Files to Device:

When you are finished with your configuration and are ready for transfers, there are two ways to transfer to your system. You can just hook up USB to Core-R without power to transfer the configuration, but the configuration will not transfer to the internal siren or internal IO until power and ignition is applied. For this

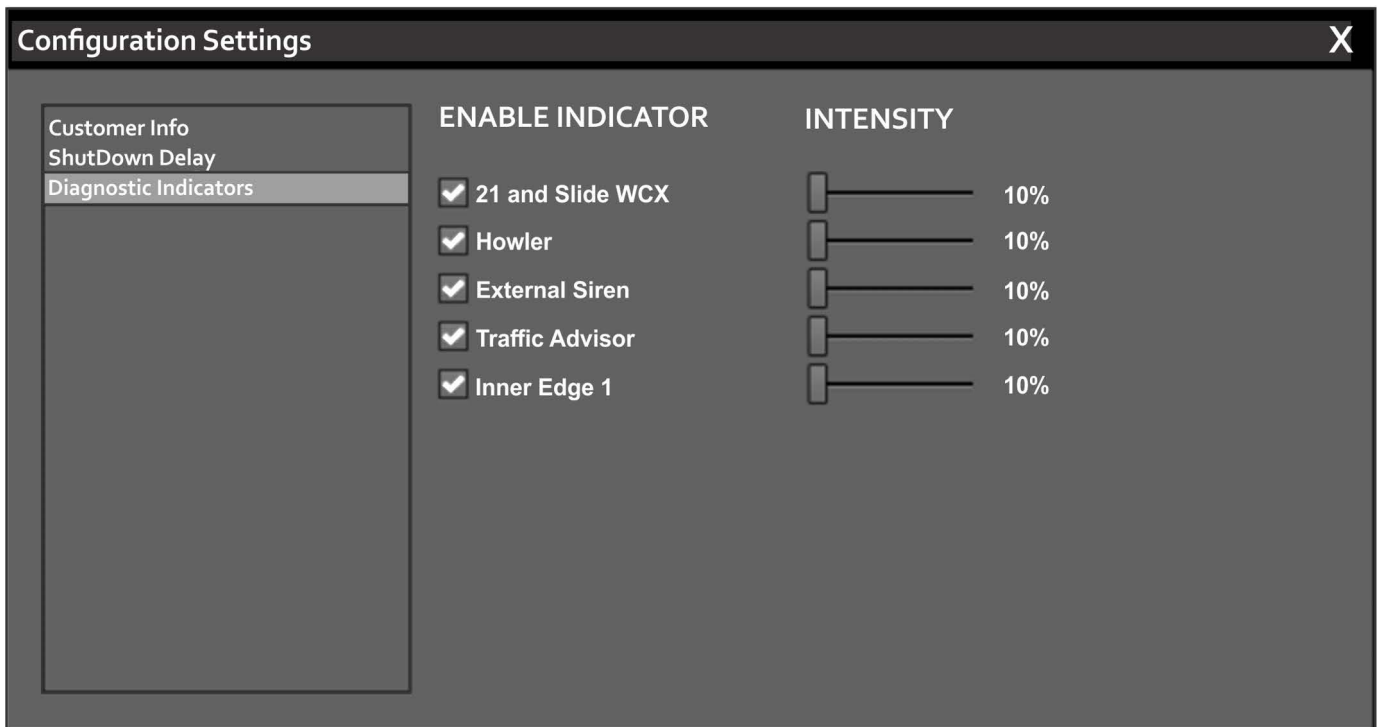

configuration to reach other WeCanX® devices, Core-R must be connected and initialized to the other devices in the configuration. Core-R's diagnostic indicators are always on and during transfer the Status indicator will be solid or flashing **White** and the activity indicator will flash **Blue** to show communication. When the configuration is finished transferring, the devices diagnostic indicator will either go solid **Green** or turn off. (This depends on whether or not you have turned device diagnostic indicators on in "configuration settings") If a large DVM tone is being transferred to an external siren or howler, the device will display a blinking **Red** indicator while it is receiving the configuration data only if the diagnostic indicator is enabled in the configuration. If the indicators are turned off, you will only have the Status and Activity indicators on the Core controller to determine the state of the configuration.

Idle States:

After Core-R is initialized and all configuration data has been propagated, Core-R will enter an Idle state and wait for inputs and instructions pending the events that you programmed. Core-R's Activity indicator is always on and will blip every time it is processing a communication. If an analog or OBDII connection is present, the activity indicator will always be showing activity in an idle state. The activity indicator will blip every time any input state change is sensed. This is helpful to see if device inputs or OBDII inputs are sensed by Core-R. When testing an input, you can watch for the Activity blip on Core-R to verify that Core-R is reading that input state change. If no blip occurs, verify you have made all the correct connections. If everything on the WeCanX® bus is initialized, there is a valid configuration and everything on the bus is in the configuration then the Core-R Status indicator will be a steady **Green**. If there are devices on the bus that are initialized but they are not present in the configuration, then the Status indicator will be steady **Green** with a **Red** blip. If there is no valid configuration on Core-R, then the Status indicator will flash **Red** only. If Core-R is not in one of these idle states, then Core-R is currently in the middle of another process as outlined in the diagnostic indicator chart.

System Shutdown:

The entire Core-R system is designed to always be connected to 10-30VDC. Every device, including main Core-R controller, has a built-in sleep function that minimizes its drain on the battery when in this mode. Applying ignition voltage to the ignition pin of Core-R will wake up the system and removing the ignition voltage will put Core-R to sleep. After about 3 seconds, all other devices connected to Core-R via WeCanX® will go to sleep and turn off diagnostic indicators.