

WHELEN[®]

ENGINEERING COMPANY INC.

51 Winthrop Road
Chester, Connecticut 06412-0684
Phone: (860) 526-9504
Internet: www.whelen.com
Sales e-mail: autosale@whelen.com
Customer Service e-mail: custserv@whelen.com

Installation Guide:
UHF2150B High Beam Flasher
2000 Chevrolet Impala

Designed for use with
Chevrolet Impala Police Package 9C1

Warnings to Installers

Whelen's emergency vehicle warning devices must be properly mounted and wired in order to be effective and safe. Read and follow all of Whelen's written instructions when installing or using this device. Emergency vehicles are often operated under high speed stressful conditions which must be accounted for when installing all emergency warning devices. Controls should be placed within convenient reach of the operator so that they can operate the system without taking their eyes off the roadway. Emergency warning devices can require high electrical voltages and/or currents. Properly protect and use caution around live electrical connections. Grounding or shorting of electrical connections can cause high current arcing, which can cause personal injury and/or vehicle damage, including fire. Many electronic devices used in emergency vehicles can create or be affected by electromagnetic interference. Therefore, after installation of any electronic device it is necessary to test all electronic equipment simultaneously to insure that they operate free of interference from other components within the vehicle. Never power emergency warning equipment from the same circuit or share the same grounding circuit with radio communication equipment. All devices should be mounted in accordance with the manufacturer's instructions and securely fastened to vehicle elements of sufficient strength to withstand the forces applied to the device. Driver and/or passenger air bags (SRS) will affect the way equipment should be mounted. This device should be mounted by permanent installation and within the zones specified by the vehicle manufacturer, if any. Any device mounted in the deployment area of an air bag will damage or reduce the effectiveness of the air bag and may damage or dislodge the device. Installer must be sure that this device, its mounting hardware and electrical supply wiring does not interfere with the air bag or the SRS wiring or sensors. Mounting the unit inside the vehicle by a method other than permanent installation is not recommended as unit may become dislodged during swerving; sudden braking or collision. Failure to follow instructions can result in personal injury. Whelen assumes no liability for any loss resulting from the use of this warning device. **PROPER INSTALLATION COMBINED WITH OPERATOR TRAINING IN THE PROPER USE OF EMERGENCY WARNING DEVICES IS ESSENTIAL TO INSURE THE SAFETY OF EMERGENCY PERSONNEL AND THE PUBLIC.**

Warnings to Users

Whelen's emergency vehicle warning devices are intended to alert other operators and pedestrians to the presence and operation of emergency vehicles and personnel. However, the use of this or any other Whelen emergency warning device does not guarantee that you will have the right-of-way or that other drivers and pedestrians will properly heed an emergency warning signal. Never assume you have the right-of-way. It is your responsibility to proceed safely before entering an intersection, driving against traffic, responding at a high rate of speed, or walking on or around traffic lanes. Emergency vehicle warning devices should be tested on a daily basis to ensure that they operate properly. When in actual use, the operator must ensure that both visual and audible warnings are not blocked by vehicle components (i.e.: open trunks or compartment doors), people, vehicles, or other obstructions. It is the user's responsibility to understand and obey all laws regarding emergency warning devices. The user should be familiar with all applicable laws and regulations prior to the use of any emergency vehicle warning device. Whelen's audible warning devices are designed to project sound in a forward direction away from the vehicle occupants. However, because sustained periodic exposure to loud sounds can cause hearing loss, all audible warning devices should be installed and operated in accordance with the standards established by the National Fire Protection Association.

Safety First

This document provides all the necessary information to allow your Whelen product to be properly and safely installed. Before beginning the installation and/or operation of your new product, the installation technician and operator must read this manual completely. Important information is contained herein that could prevent serious injury or damage.

- **Proper installation of this product requires the installer to have a good understanding of automotive electronics, systems and procedures.**
- **Whelen Engineering requires the use of waterproof butt splices and/or connectors if that connector could be exposed to moisture.**
- **Any holes, either created or utilized by this product, should be made both air- and watertight using a sealant recommended by your vehicle manufacturer.**
- **Failure to use specified installation parts and/or hardware will void the product warranty.**
- **If mounting this product requires drilling holes, the installer MUST be sure that no vehicle components or other vital parts could be damaged by the drilling process. Check both sides of the mounting surface before drilling begins. Also de-burr the holes and remove any metal shards or remnants. Install grommets into all wire passage holes.**
- **If this manual states that this product may be mounted with suction cups, magnets, tape or Velcro®, clean the mounting surface with a 50/50 mix of isopropyl alcohol and water and dry thoroughly.**
- **Do not install this product or route any wires in the deployment area of your air bag. Equipment mounted or located in the air bag deployment area will damage or reduce the effectiveness of the air bag, or become a projectile that could cause serious personal injury or death. Refer to your vehicle owner's manual for the air bag deployment area. The User/Installer assumes full responsibility to determine proper mounting location, based on providing ultimate safety to all passengers inside the vehicle.**
- **For this product to operate at optimum efficiency, a good electrical connection to chassis ground must be made. The recommended procedure requires the product ground wire to be connected directly to the NEGATIVE (-) battery post (this does not include products that use cigar power cords).**
- **If this product uses a remote device for activation or control, make sure that this device is located in an area that allows both the vehicle and the device to be operated safely in any driving condition.**
- **Do not attempt to activate or control this device in a hazardous driving situation.**
- **It is recommended that these instructions be stored in a safe place and referred to when performing maintenance and/or reinstallation of this product.**
- **FAILURE TO FOLLOW THESE SAFETY PRECAUTIONS AND INSTRUCTIONS COULD RESULT IN DAMAGE TO THE PRODUCT OR VEHICLE AND/OR SERIOUS INJURY TO YOU AND YOUR PASSENGERS!**

IMPORTANT NOTES:

- The use of a flashing headlight system may be regulated by state, county, or municipal authorities. It is the responsibility of the end user to comply with these regulations.
- Before attempting the installation of the UHF2150B headlight flasher, thoroughly read and understand instructions and steps shown below.
- Disconnect the battery from the electrical system before attempting any part of this installation.
- Have your “Impala Police Package Owner’s Manual Supplement” available for reference.

Installation:

1. Locate and remove the three, plastic fasteners that secure the cowl panel covering the area between the top of the radiator support and the top of the grille. Remove this panel from the vehicle.

NOTE: Each fastener must be returned to its original location when re-installing this panel.

2. Locate and remove the two, passenger-side headlight pillar bolts (see fig. 1).

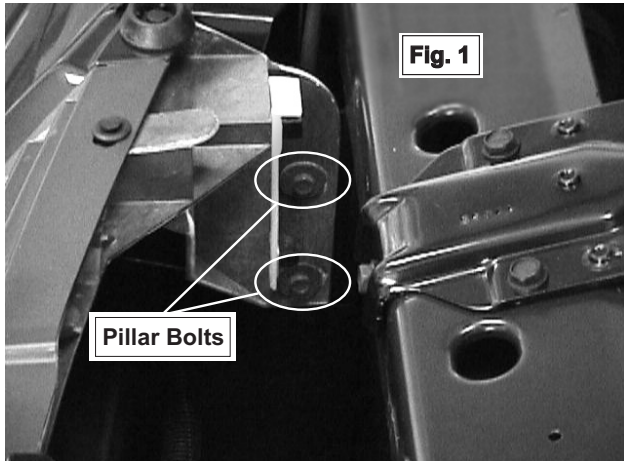

3. Using the bolts removed in the previous step, secure the headlight flasher bracket to the pillar. Make sure that the flasher is oriented as shown in fig. 2.
4. The necessary electrical connections will now be made. Follow the appropriate procedure for your vehicle.

Wiring:

Vehicles equipped with Chevrolet Option SEO 6J3

1. Disconnect the headlamp harness’ water-proof connection adjacent to the installed flasher.

2. Plug the water-proof flasher plugs into the appropriate water-proof harness connection referenced in the previous step. Make sure that these plugs fully engage the harness receptacles.
3. Locate the PINK, 16-gauge control wire under the instrument panel (refer to your “Impala Police Package Owner’s Manual Supplement” for specific information regarding location of this wire).
4. Connect this PINK wire to a customer supplied switch.

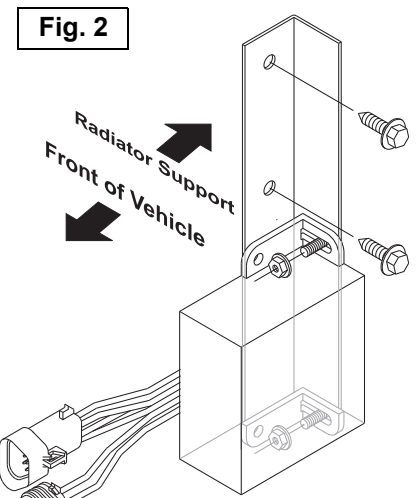

Vehicles without Chevrolet Option SEO 6J3

1. Disconnect the headlamp harness’ water-proof connection adjacent to the installed flasher.
2. The flasher’s pin-housing connector includes an ORANGE wire. Cut this wire at the connector.
3. Plug the water-proof flasher connector into the appropriate water-proof harness connection referenced in the previous step. Make sure that these connectors fully engage the harness connectors.
4. Using appropriately sized wire, extend this ORANGE wire to a customer-supplied switch.

Flash Pattern Selection:

There are 4 available flashrates for the UHF2150B. These rates are determined by two jumper wires located on the rear of the flasher module; WHITE/RED and WHITE/VIOLET. The following table defines the available flashrates.

WHT/RED	WHT/VIO	Flashrate
Intact	Intact	Moduflash
CUT	Intact	280 SF Alternating
Intact	CUT	140 DF Alternating/ 140 SF Simultaneous
CUT	CUT	140 DF Alternating/ 280 SF Alternating

SF = Single Flash per min.
DF = Double Flash Per Min.